

## AABP Pressure Sensor Series

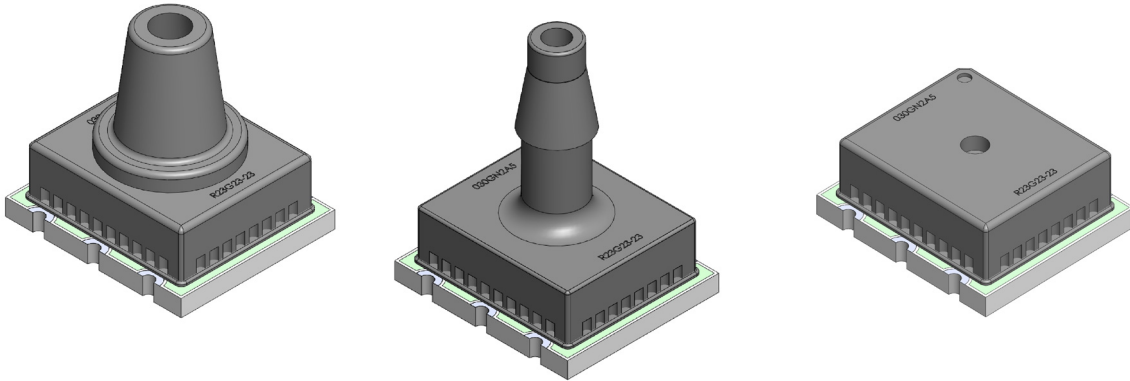

### Table of Contents

Features & Applications.....	2
Standard Pressure Ranges .....	2
Pressure Sensor Maximum Ratings.....	2
Environmental Specifications .....	2
Wetted Materials.....	2
Performance Characteristics.....	3
Sensor Output at Significant Percentages.....	4
Transfer Functions .....	4
Digital Interface Data Format .....	5
I2C Interface .....	5-6
SPI Interface.....	7
Interface Timing Diagrams.....	8
How to Order Table .....	9
Pinouts .....	9
Product Marking .....	10
Pad Layout .....	10
Package Drawings.....	11

### Introduction

The AABP series are piezoresistive silicon pressure sensors offering a digital or ratiometric analog output over the specified pressure and temperature range.

The sensors in this series are fully calibrated and temperature compensated using on board Application Specific Integrated Circuit (ASIC) in a compact package.



## Features

- Compact footprint 8mm x 7mm
- Total Error Band  $\pm 1.5\%$ FSS
- Wide Pressure Range: 5PSI to 150PSIG
- Output: Digital I2C or SPI or Ratiometric Analog
- Single Power Supply of 3.3V or 5V
- Calibrated Over Temperature Range: 0°C to 50°C [32°F to 122°F]

## Applications

- Medical Instrumentation
- Environmental Controls
- HVAC

### Pressure Ranges

Device	Pressure Range	Proof Pressure <sup>1</sup>	Burst Pressure <sup>2</sup>
005G	0 to 5 PSIG	15 PSIG	25 PSIG
015G	0 to 15 PSIG	45 PSIG	75 PSIG
030G	0 to 30 PSIG	90 PSIG	150 PSIG
060G	0 to 60 PSIG	120 PSIG	200 PSIG
100G	0 to 100 PSIG	200 PSIG	250 PSIG
150G	0 to 150 PSIG	200 PSIG	250 PSIG

Note 1: Proof Pressure: The maximum pressure which may safely be applied to the sensor for it to remain in specification once pressure is returned to the operating pressure range.

Note 2: Burst pressure: The maximum pressure that may be applied to the sensor without causing escape of pressure media. The sensor should not be expected to function after exposure to any pressure beyond the burst pressure.

Pressure Sensor Maximum Ratings		Environmental Specifications	
<b>Supply Voltage (Vs)</b>	6 Vdc	<b>Temperature Ranges</b>	
<b>Voltage on any pin</b>	-0.3 to Vs+ 0.3 Vdc	Operating	-40°C to 85°C [-40°F to 185°F]
<b>Digital Interface Frequency</b>		Compensated	0°C to 50°C [32°F to 122°F]
I2C	100 to 400 kHz	Storage	-40°C to 85°C [-40°F to 185°F]
SPI	50 to 800 kHz	<b>Humidity Limits (non condensing)</b>	0 to 95% RH
<b>Reflow Temperature &amp; Time</b>	15s max at 250°C	<b>Media</b>	non-corrosive gases
		<b>Wetted Materials</b>	
		Alumina ceramic, high temp polyamide, epoxy, silicone, glass, gold, aluminum	



## Performance Characteristics

Parameter	Analog			Digital			Units	Notes
	Min	Typ	Max	Min	Typ	Max		
<b>Supply Voltage (Vs)</b>								
3.3 Vdc	3.00	3.30	3.60	3.00	3.30	3.60	VDC	1, 2, 3
5 Vdc	4.75	5.00	5.25	4.75	5.00	5.25	VDC	1, 2, 3
<b>Supply Current</b>								
3.3 Vdc	-	2.1	2.8	-	3.1	3.9	mA	-
5 Vdc	-	2.7	3.8	-	3.7	4.6	mA	-
Sleep Mode Option	-	-	-	-	1	10	µA	-
<b>Compensated Temperature Range</b>	0 [32]	-	50 [122]	0 [32]	-	50 [122]	°C [°F]	4
<b>Temperature Output Option</b>	-	-	-	-	±2.0	-	°C	5
<b>Startup Time (Powerup to Data Ready)</b>	-	-	5	-	-	3	ms	-
<b>Response Time</b>	-	1.00	-	-	0.46	-	ms	-
<b>Clipping Limit</b>								
Upper	-	-	97.50	-	-	-	%Vs	-
Lower	2.5	-	-	-	-	-	%Vs	-
<b>I2C/SPI Voltage Level</b>								
Low	-	-	-	-	-	20	%Vs	-
High	-	-	-	80	-	-	%Vs	-
<b>Pull Up on SDA/MISO, SCL/SCLK, SS</b>	-	-	-	1	-	-	kΩ	-
<b>Total Error Band (TEB)</b>	-	-	±1.5	-	-	±1.5	%FSS	6, 7
<b>Accuracy (BFSL)</b>	-	-	±0.25	-	-	±0.25	%FSS	8
<b>Long Term Stability (1000 hrs, 25°C [77°F])</b>	-	-	±0.25	-	-	±0.25	%FSS	-
<b>Output Resolution</b>								
	0.03	-	-	-	-	-	%FSS	-
	-	-	-	12	-	-	bits	-

### Specification Notes

NOTE 1: SPECIFICATIONS APPLY AT 3.3 VDC OR 5.0 VDC TO SENSORS ORDERED WITH THE CORRESPONDING SUPPLY VOLTAGE OPTION ONLY.

NOTE 2: RATIOMETRICITY OF THE SENSOR (OUTPUT IS PROPORTIONAL TO SUPPLY VOLTAGE) IS ACHIEVED WITHIN THE SPECIFIED OPERATING VOLTAGE.

NOTE 3: THE SENSOR IS NOT REVERSE POLARITY PROTECTED. INCORRECT CONNECTION OF SUPPLY VOLTAGE OR GROUND MAY CAUSE ELECTRICAL FAILURE.

NOTE 4: COMPENSATED TEMPERATURE RANGE IS THE TEMPERATURE RANGE OVER WHICH THE SENSOR WILL PRODUCE AN OUTPUT PROPORTIONAL TO THE PRESSURE WITHIN THE SPECIFIED PERFORMANCE LIMITS.

NOTE 5: TEMPERATURE OUTPUT OPTION: TYPICAL TEMPERATURE OUTPUT ERROR OVER THE COMPENSATED TEMPERATURE RANGE OF 0°C TO 50°C. OPERATING IN SLEEP MODE MAY AFFECT TEMPERATURE OUTPUT ERROR DEPENDING ON DUTY CYCLE.

NOTE 6: TOTAL ERROR BAND (TEB) IS THE COMBINATION OF ERRORS INCLUDING OFFSET, SPAN, LINEARITY, PRESSURE HYSTERESIS, TEMPERATURE EFFECT ON OFFSET, AND TEMPERATURE EFFECT ON SPAN.

NOTE 7: FULL SCALE SPAN (FSS): THE ALGEBRAIC DIFFERENCE BETWEEN THE OUTPUT MEASURED AT THE MAXIMUM AND MINIMUM LIMITS OF THE SPECIFIED PRESSURE RANGE.

NOTE 8: ACCURACY: THE MAXIMUM DEVIATION IN OUTPUT FROM A BEST FIT STRAIGHT LINE (BFSL) FITTED TO THE OUTPUT MEASURED OVER THE PRESSURE RANGE AT 25°C [77°F] INCLUDING ALL ERRORS FROM PRESSURE NON-LINEARITY, PRESSURE HYSTERESIS, AND NON-REPEATABILITY.

## Sensor Output at Significant Percentages (Digital Version Only)

% OUTPUT	DIGITAL COUNTS	
	DECIMAL	HEX
0	0	0x0000
10	1638	0x0666
50	8192	0x2000
90	14746	0x399A
100	16383	0x3FFF

## Transfer Functions

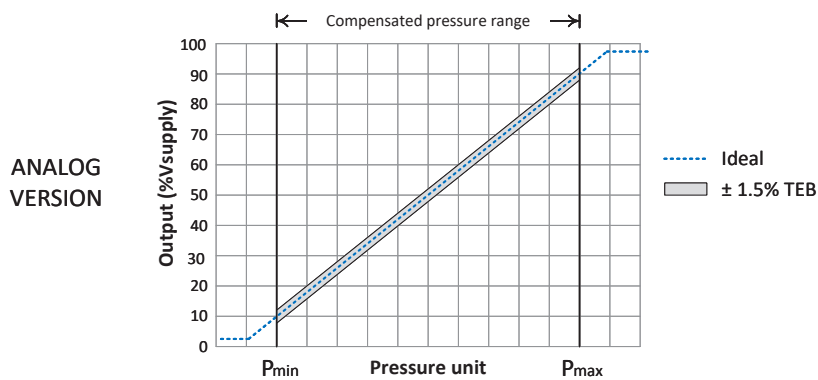

$$\text{Pressure (PSI)} = P_{min} + 1.25 \times \left[ \frac{(\text{Output}(V) - (0.1 \times V_s))}{V_s} \right] \times (P_{max} - P_{min})$$

Where:

*P<sub>max</sub> and P<sub>min</sub> are in units of PSI*

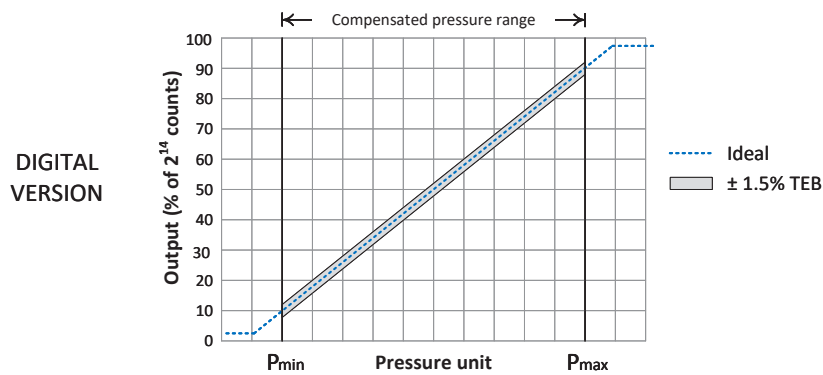

$$\text{Pressure (PSI)} = P_{min} + 1.25 \times \left[ \frac{(\text{Output}(\text{counts}) - 1638)}{16384} \right] \times (P_{max} - P_{min})$$

Where:

*P<sub>max</sub> and P<sub>min</sub> are in units of PSI*

## Digital Interface Data Format

For either type of digital interface, the format of data returned from the sensor is the same. The first 16 bits consist of the 2 Status bits followed by the 14-bit the pressure value. The third byte provides the 8 most significant bits of the measured temperature; the fourth byte provides the 3 least significant bits of temperature, followed by 5 bits of undefined filler data. With either interface, the host may terminate the transfer after receiving the first two bytes of data from the sensor, or following the third byte (if just the most-significant 8 bits of temperature are needed). Refer to Table 1 for the overall data format of the sensor. Table 2 shows the Status Bit definition.

**Table 1 - Output Data Format**

D[31:30]	D[29:24]	D[23:16]	D[15:8]	D[7:5]	D[4:0]
S[1:0]	P[13:8]	P[7:0]	T[10:3]	T[2:0]	X[4:0]
Status	Pressure MSB	Pressure LSB	Temperature MSB	Temperature LSB	Filler bits (Undefined)

Bit Definitions:

Status (S): Normal/command / busy / diagnostic

Pressure (P): Digital pressure reading

Temperature (T): Compensated temperature reading

**Table 2- Status Bit Definitions**

[00]	[01]	[10]	[11]
Current Data, no errors.	(Reserved)	Stale Data: Not updated since last read.	Error Condition: electrical fault or configuration invalid.

## I<sup>2</sup>C Interface

### I<sup>2</sup>C Communications Overview

The I<sup>2</sup>C interface uses a set of signal sequences for communication. The following is a description of the supported sequences and their associated mnemonics. Refer to Figure 1 for the associated usage of the following signal sequences.

**Bus not Busy (I):** During idle periods both data line (SDA) and clock line (SCL) remain HIGH.

**START condition (ST):** A HIGH to LOW transition of SDA line while the clock (SCL) is HIGH is interpreted as START condition. START conditions are always set by the master. Each initial request for a pressure value has to begin with a START condition.

**Slave address (An):** The I<sup>2</sup>C-bus requires a unique address for each device. After setting a START condition the master sends the address byte containing the 7 bit sensor address followed by a data direction bit (R/W). A "0" indicates a transmission from master to slave (WRITE), a "1" indicates a data request (READ).

**Acknowledge (A or N):** Data is transferred in units of 8 bits (1 byte) at a time, MSB first. Each data-receiving device, whether master or slave, is required to pull the data line LOW to acknowledge receipt of the data. The Master must generate an extra clock pulse for this purpose. If the receiver does not pull the data line down, a NACK condition exists, and the slave transmitter becomes inactive. The master determines whether to send the last command again or to set the STOP condition, ending the transfer.

**DATA valid (Dn):** State of data line represents valid data when, after a START condition, data line is stable for duration of HIGH period of clock signal. Data on line must be changed during LOW period of clock signal. There is one clock pulse per data bit.

**DATA operation:** The sensor starts to send 4 data bytes containing the current pressure and temperature values. The transmission may be halted by the host after any of the bytes by responding with a NACK.

**STOP condition (P):** LOW to HIGH transition of the SDA line while clock (SCL) is HIGH indicates a STOP condition. STOP conditions are always generated by the master.

**Figure 1 - I<sup>2</sup>C Communication Diagram**

I<sup>2</sup>C Communications Diagram

1. Start All ( to wake sensor from Sleep mode, Zero ADC, read Temperature and read Pressure )

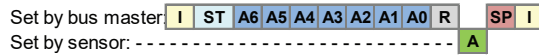

2. Start Pressure ( to wake sensor from Sleep mode and read Pressure only )

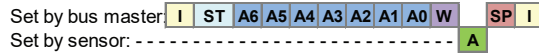

3. Read Data ( with examples of reading pressure, pressure plus 8 bits of temperature and pressure plus 11 bits of temperature )

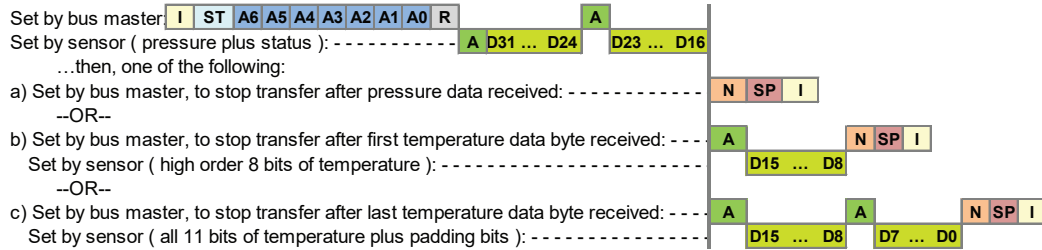

<u>Bus states</u>				
Idle:	I			
Start:	ST			
Stop:	SP			
Ack:	A			
Nack:	N			
"Read" bit (1):	R			
"Write" bit (0):	W			

<u>Sensor Address</u>	
A6 ... A0	

<u>Data format</u>	
Status:	D31 D30
Pressure data:	D29 ... D16
Temperature data:	D15 ... D5
(padding bits:)	D4 ... D0

Figure 1 illustrates the sequence of signals set by both the host and the sensor for each command. Note that for the DataRead command, the host has the option of responding to the second or third bytes of data with a NACK instead of ACK. This terminates the data transmission after the pressure data, or after the pressure data and upper byte of temperature, have been transmitted. See Figure 4 for the I<sup>2</sup>C timing details.

I<sup>2</sup>C Exceptions

1. Sending a Start condition, then a Stop condition, without any transitions on the CLK line, creates a communication error for the next communication, even if the next start condition is correct and the clock pulse is applied. A second Start condition must be set, which clears the error and allows communication to proceed.
2. The Restart condition—a falling SDA edge during data transmission when the CLK clock line is still high— creates the same stall/deadlock. In the following data request, an additional Start condition must be sent for correct communication.
3. A falling SDA edge is not allowed between the start condition and the first rising SCL edge. If using an I<sup>2</sup>C address with the first bit 0, SDA must be held low from the start condition through the first bit.

## SPI Interface

### SPI Command Sequence

DLVR sensors using the SPI interface option provide 3 signals for communication: SCLK, SS (Slave Select), and MISO. This read-only signaling uses a hardware protocol to control the sensor, differing slightly with the speed/power option selected as described below:

Fast(F), Noise Reduced(N) and Low-Power(L) Configurations: After power-up, the part enters Free Running mode and begins its periodic conversion cycle, at the interval determined by the programmed Power/Speed option. This is the simplest configuration. The only bus interaction with the host is the SPI DataRead operations. Polling the sensor at a rate slower than the internal update rate will minimize bus activity and ensure that new values are presented with each transfer. Note that the Status bits should still be checked to verify updated data and the absence of error conditions.

### SPI Bit Pattern

The sequence of bits and bus signals are shown in the following illustration (Figure 2). Refer to Figure 3 in the Interface Timing Diagram section for detailed timing data. As previously described, the incoming data may be terminated by raising SS after 2, 3, or 4 bytes have been received as illustrated below.

**Figure 2 - SPI Bit Pattern**

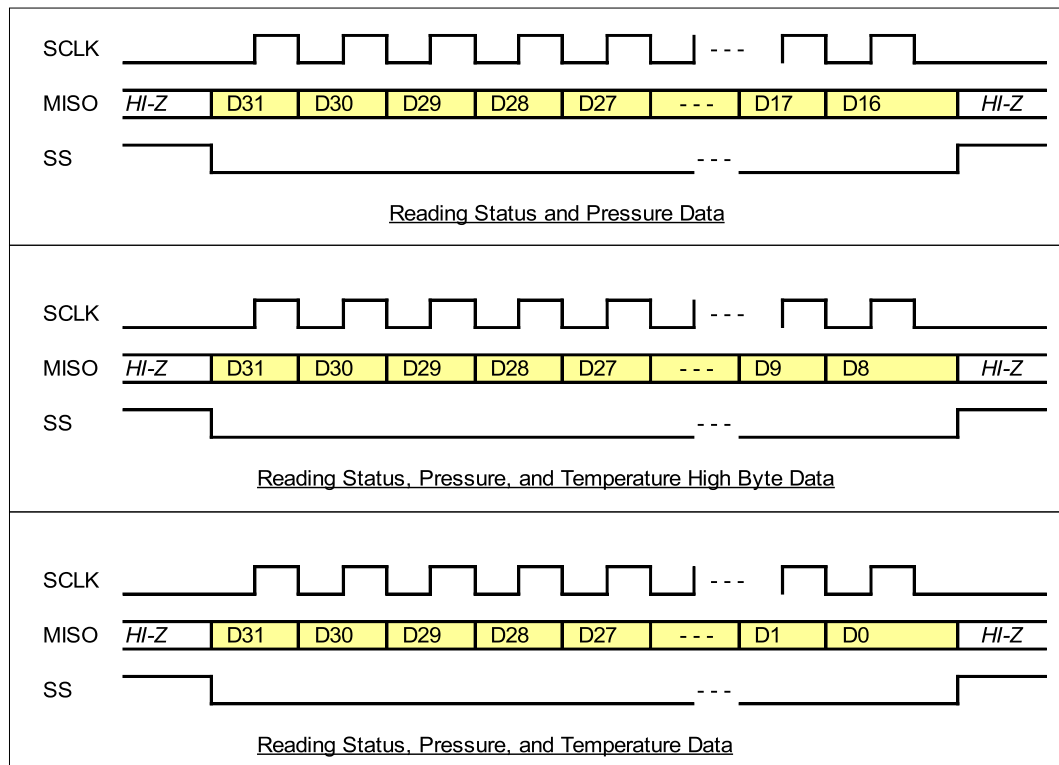

## Interface Timing Diagrams

Figure 3: SPI Timing Diagram

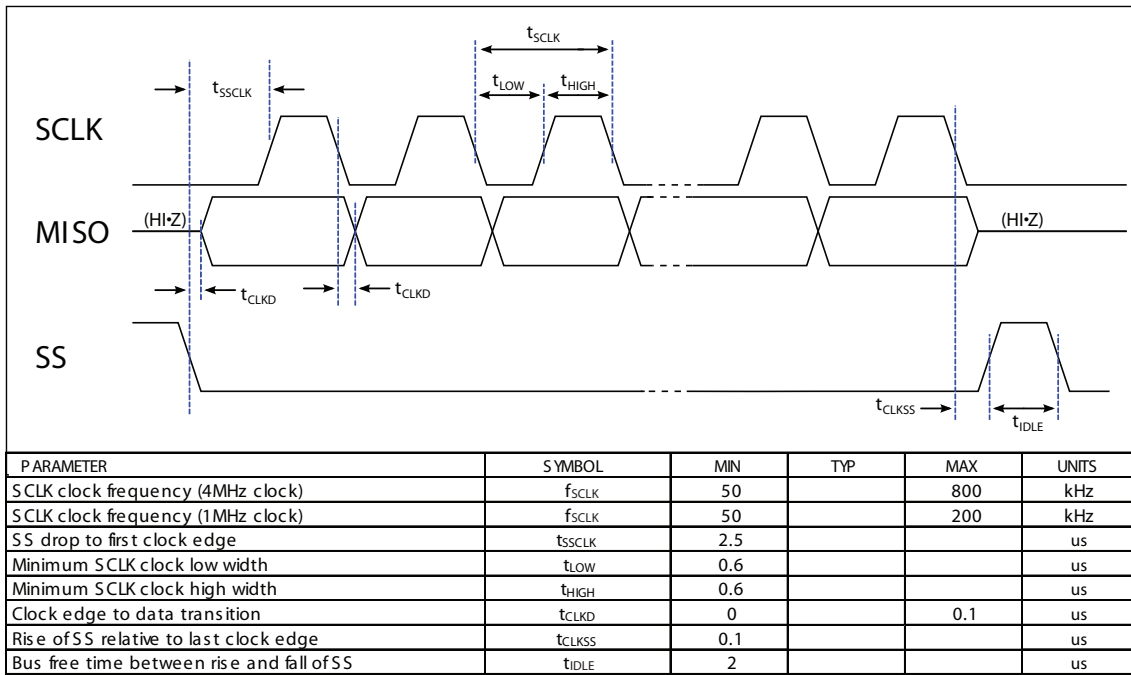
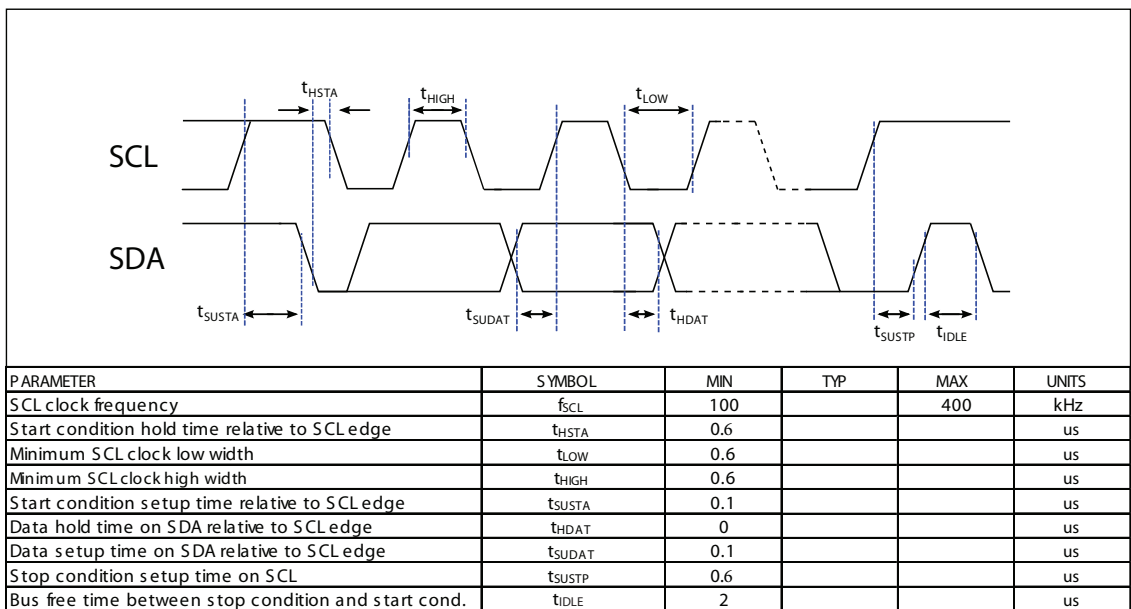
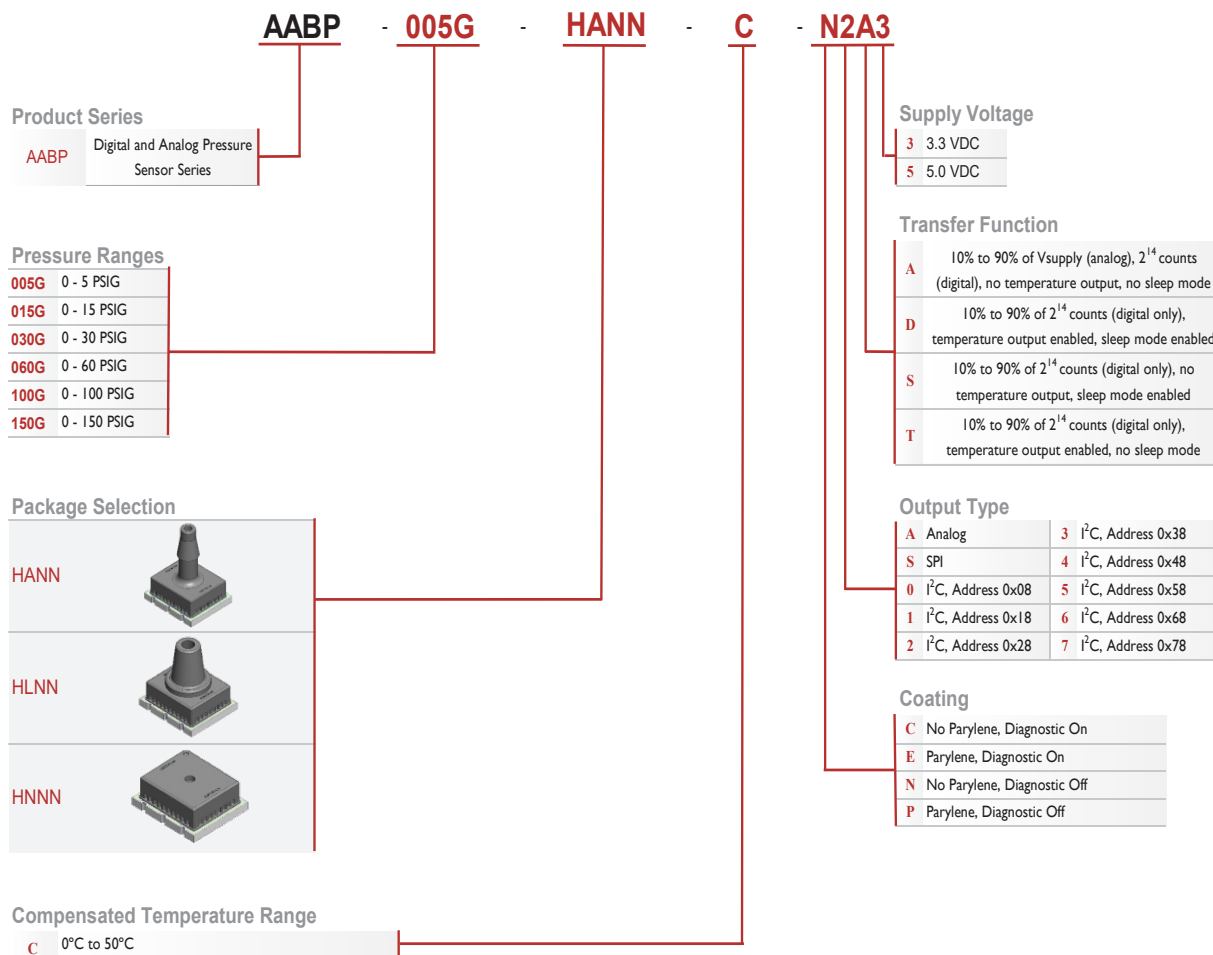

Figure 4: I<sup>2</sup>C Timing Diagram



## How to Order Table



Note: Custom pressure ranges are available. Please contact the factory for more information.

### Pinouts

OUTPUT TYPE	PIN 1	PIN 2	PIN 3	PIN 4	PIN 5	PIN 6
Analog	GND	N/C	Vout	N/C	N/C	Vs
I2C	GND	Vs	INT	N/C	SDA	SCL
SPI	GND	Vs	SS	N/C	MISO	SCLK

\* N/C: Not internally connected

## Product Marking

Product Marking Example for Part Number:  
AABP-005G-HANN-C-N2A3

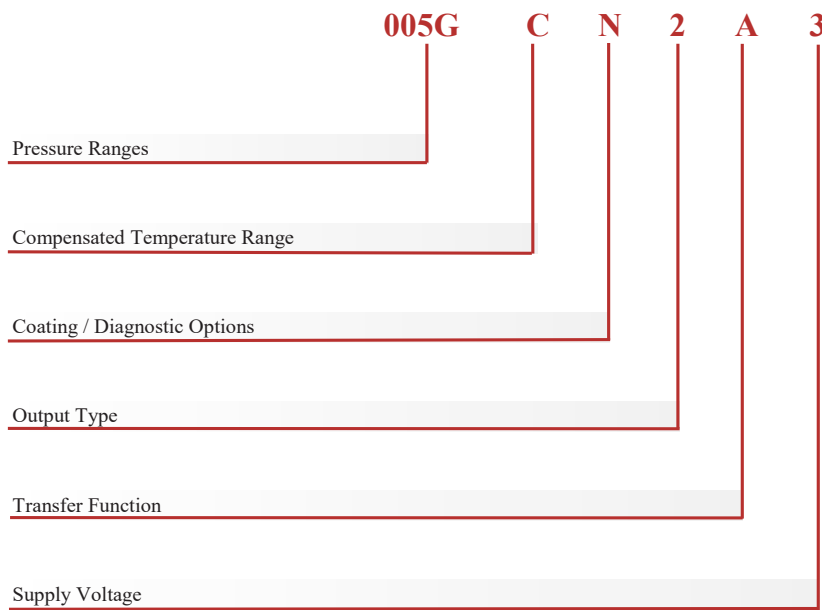
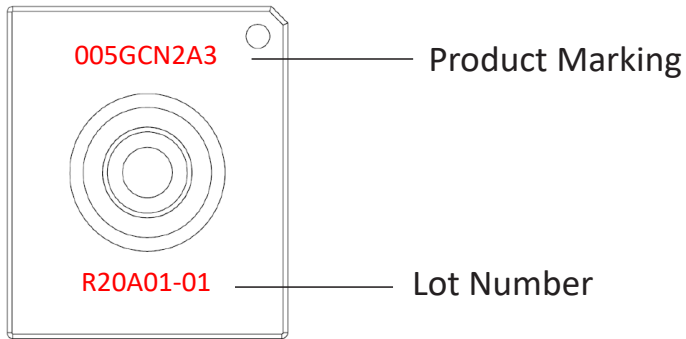

## Suggested PAD Layout

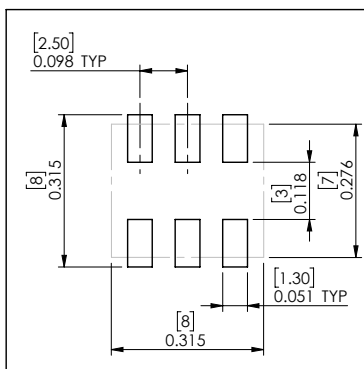

PAD-36

AN: Single Axial Barbed Port

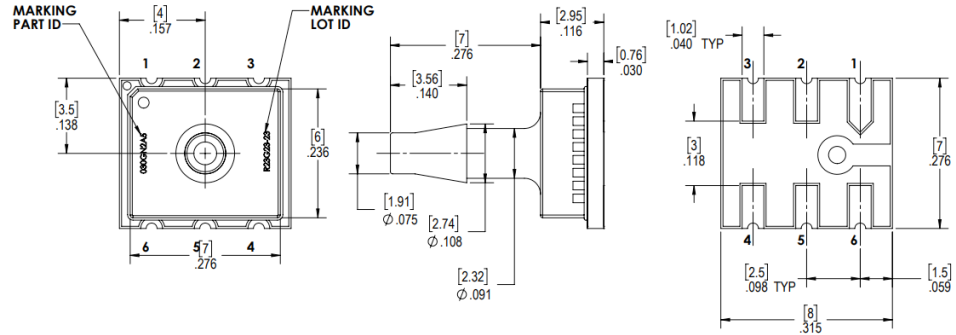
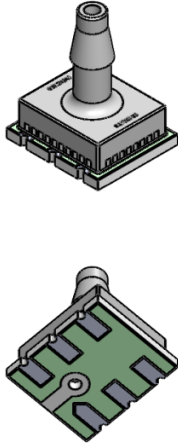

LN: Single Axial Barbless Port

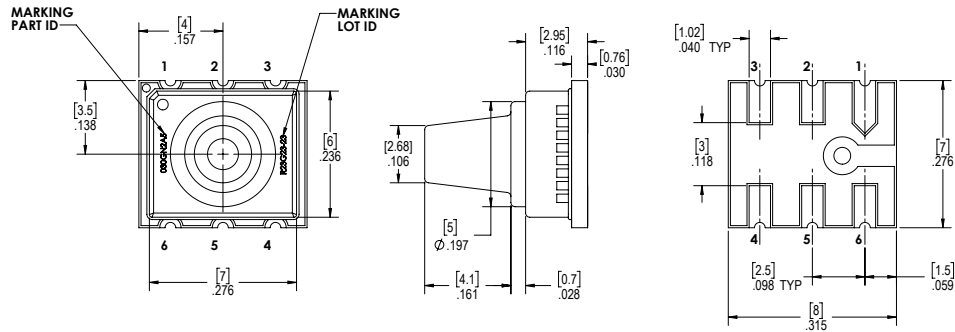
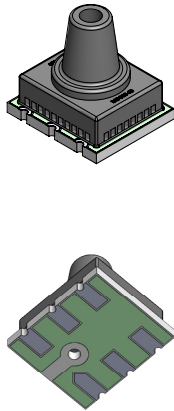

NN: No Port

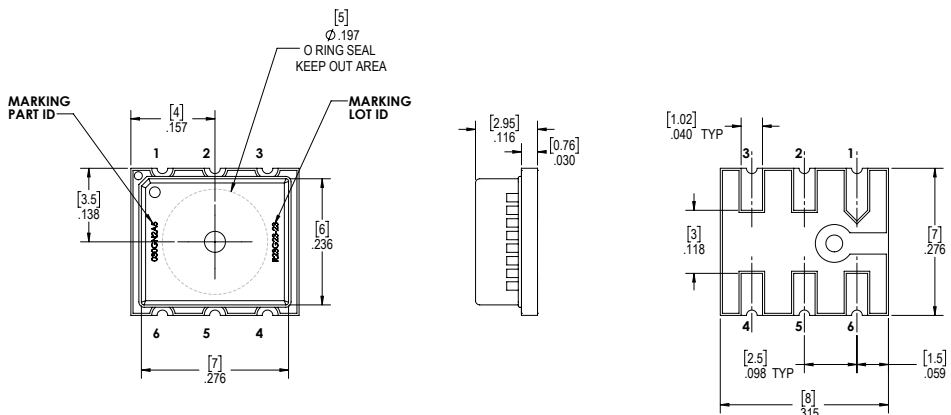
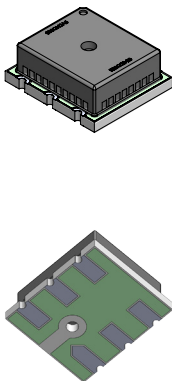

All Sensors reserves the right to make changes to any products herein. All Sensors does not assume any liability arising out of the application or use of any product or circuit described herein, neither does it convey any license under its patent rights nor the rights of others.