

## ELVH Series - Analog and Digital Pressure Sensor Product Families

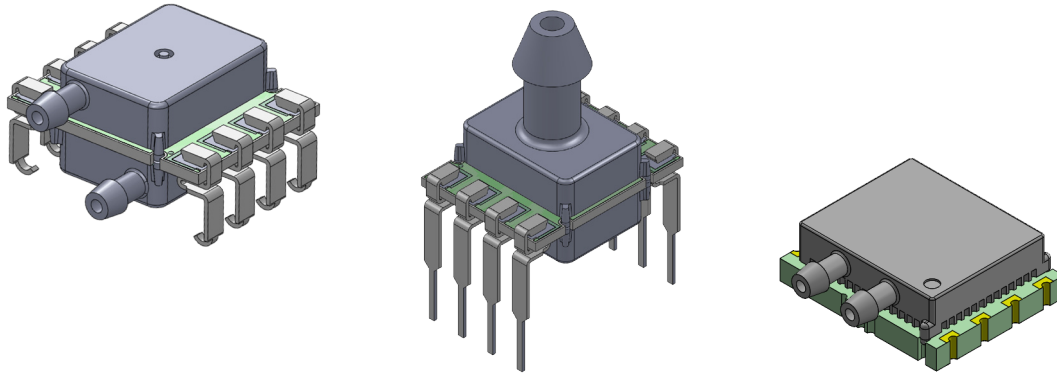

### Table of Contents

Features & Applications .....	2
Maximum Ratings .....	2
Environmental Specifications .....	2
Equivalent Circuit.....	2
Product Family Highlights .....	3
Pressure Ranges.....	4-5
Performance Characteristics.....	6
How to Order Tables.....	7
Parylene Coating.....	8
Soldering Recommendations.....	8
Evaluation Kit.....	8
Sensor Application Information.....	9-10
Digital Interfaces (I2C & SPI).....	11-14
Pin Indicator & Product Marking .....	15
Pressure Tubing Recommendations .....	16
Pad Layouts.....	16
Dimensional Package Drawings	
DIP.....	17-19
SIP .....	20-22
SMT .....	23-25

### Introduction

The ELVH Analog and Digital Pressure Sensor Series features All Sensors' ultra low pressure CoBeam<sup>2</sup>™ Technology. This innovative sensing element technology provides best-in-class stability for low and ultra low pressure ranges, with the ability to customize calibrations and pressure ranges from a proven world class supplier.

The ELVH series gives design engineers outstanding flexibility with an exceptional number of choices in package combination.

The digital interface eases integration of the sensors into a variety of process control and measurement systems, allowing direct connection to serial communications channels.

These calibrated and compensated sensors provide accurate, stable output over a wide temperature range. This series is intended for use with non-corrosive, non-ionic working fluids such as air and other dry gases. A protective parylene coating is optionally available.



## Features

- Pressure Ranges from  $\pm 0.5$  inH<sub>2</sub>O to 150 psi and  $\pm 2.5$  mbar to  $\pm 10$  bar
- Precision ASIC Conditioning
- Digital I<sup>2</sup>C or SPI Interface or Analog Only Options
- 3.3V and 5V Supply Voltage Options

## Applications

- Medical Devices
- Medical Instrumentation
- Respiratory
- Portable / Hand-Held Equipment
- Environmental Controls
- Environmental Instrumentation
- Environmental Monitoring
- HVAC
- Industrial Controls
- Altimeters
- Chemical Analysis
- Meteorology

## Wetted Media

- Silicon
- RTV
- Gold
- Ceramic
- Epoxy
- Nylon Plastic
- Aluminum

Pressure Sensor Maximum Ratings		Environmental Specifications	
<b>Supply Voltage (Vs)</b>	2.7 to 5.5 Vdc	<b>Temperature Ranges</b>	
<b>Lead Temperature (soldering 2-4 sec.)</b>	270°C	Compensated: Standard	0°C to 50°C
<b>Device Temperature (reflow soldering)</b>	245°C	Industrial	-20°C to 85°C
		Operating	-40°C to 85°C
		Storage	-40°C to 125°C
		<b>Humidity Limits (non condensing)</b>	0 to 95% RH

## Equivalent Circuit

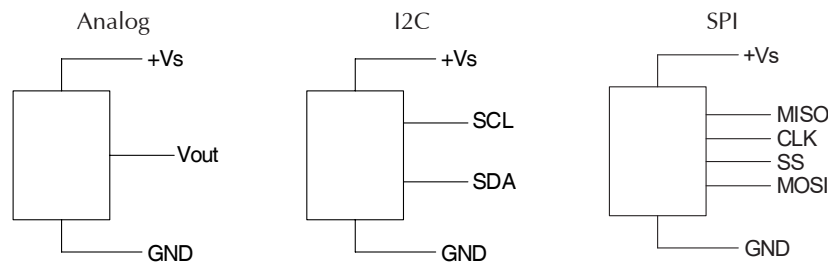

See package drawings for pinouts.

## ELVH Product Family Highlights

---

- 0.5 inH<sub>2</sub>O up to 60 inH<sub>2</sub>O and 1 psi up to 150 psi pressure ranges. 2.5 mbar up to 10 bar pressure ranges
- Offered in Differential, Gage and Absolute pressure modes
- 0 to 50°C and -20 to 85°C Temperature compensation options
- Output offered as
  - Digital I<sup>2</sup>C or SPI in 14 bit output or Ratiometric Analog option
  - 6 unique I<sup>2</sup>C address options
  - 4 unique transfer function options
- 3.3V and 5V Supply Voltage offerings
- Available in Numerous Port options:
  - No port
  - Barbed axial port
  - Needle big port
  - Side port
  - Other packages also available, check with factory
- Numerous lead options:
  - SMT J-lead
  - DIP lead
  - SIP lead
- Parylene Coating offered on pressure ranges of 10 inH<sub>2</sub>O and 25 mbar and above

## ELVH Series Pressure Ranges

Pressure Range <sup>1</sup>				Proof Pressure <sup>2</sup>		Burst Pressure <sup>3</sup>		Common Mode Pressure <sup>4</sup>		
CODE	Pmin inH2O	Pmax	Pressure Mode	kPa	inH2O	kPa	inH2O	kPa	inH2O	kPa
F50D	-0.5	0.5	Differential	0.1	270	67	415	103	415	103
L01D	-1	1	Differential	0.2	270	67	415	103	415	103
L02D	-2	2	Differential	0.5	270	67	415	103	415	103
L04D	-4	4	Differential	1.0	300	75	415	103	415	103
L05D	-5	5	Differential	1.2	300	75	415	103	415	103
L10D	-10	10	Differential	2.5	350	87	415	103	415	103
L20D	-20	20	Differential	5.0	350	87	415	103	415	103
L30D	-30	30	Differential	7.5	350	87	415	103	415	103
L60D	-60	60	Differential	14.9	350	87	415	103	415	103
L01G	0	1	Gage	0.2	270	67	415	103	415	103
L02G	0	2	Gage	0.5	270	67	415	103	415	103
L04G	0	4	Gage	1.0	300	75	415	103	415	103
L05G	0	5	Gage	1.2	300	75	415	103	415	103
L10G	0	10	Gage	2.5	350	87	415	103	415	103
L20G	0	20	Gage	5.0	350	87	415	103	415	103
L30G	0	30	Gage	7.5	350	87	415	103	415	103
L60G	0	60	Gage	14.9	350	87	415	103	415	103
CODE	Pmin psi	Pmax	Pressure Mode	kPa	psi	kPa	psi	kPa	psi	kPa
001D	-1	1	Differential	7	10	69	15	103	15	103
005D	-5	5	Differential	34	15	103	15	103	15	103
015D	-15	15	Differential	103	30	207	150	1034	250	1724
030D	-30	30	Differential	207	60	414	250	1724	250	1724
060D	-60	60	Differential	414	120	827	250	1724	250	1724
001G	0	1	Gage	7	10	69	15	103	15	103
005G	0	5	Gage	34	15	103	15	103	15	103
015G	0	15	Gage	103	30	207	75	517	250	1724
030G	0	30	Gage	207	60	414	150	1034	250	1724
060G	0	60	Gage	414	120	827	250	1724	250	1724
100G	0	100	Gage	690	250	1724	250	1724	250	1724
150G	0	150	Gage	1034	250	1724	250	1724	250	1724
015A	0	15	Absolute	103	15	103	15	103	15	103
030A	0	30	Absolute	207	60	414	150	1034	250	1724
060A	0	60	Absolute	414	120	827	250	1724	250	1724
100A	0	100	Absolute	690	250	1724	250	1724	250	1724
150A	0	150	Absolute	1034	250	1724	250	1724	250	1724

**ELVH Pressure Ranges Specification Notes**

- Note 1: Pressure ranges in Pa and kPa are expressed as an approximate value.
- Note 2: Differential Proof Pressure: The maximum pressure which may safely be applied to one port of the product for it to remain in specification once pressure is returned to the operating pressure range. Exposure to higher pressures may cause permanent damage to the product.
- Note 3: Differential Burst Pressure: The maximum pressure that may be applied to one port of the product without causing escape of pressure media. Product should not be expected to function after exposure to any pressure beyond the burst pressure.
- Note 4: Common Mode Pressure: The maximum pressure that can be applied simultaneously to both ports of a differential pressure sensor without causing escape of pressure media. Product should not be expected to function after exposure to any pressure beyond the this maximum pressure.



## ELVH Series Pressure Ranges (Cont'd)

Pressure Range <sup>1</sup>				Proof Pressure <sup>2</sup>			Burst Pressure <sup>3</sup>		Common Mode Pressure <sup>4</sup>	
CODE	P <sub>min</sub> mbar	P <sub>max</sub>	Pressure Mode	kPa	mbar	kPa	mbar	kPa	mbar	kPa
MF25D	-2.5	2.5	Differential	0.25	675	68	1034	103	1034	103
M005D	-5.0	5	Differential	0.5	675	68	1034	103	1034	103
MF12D	-12.5	12.5	Differential	1.25	750	75	1034	103	1034	103
M025D	-25	25	Differential	2.5	850	85	1034	103	1034	103
M050D	-50	50	Differential	5	850	85	1034	103	1034	103
M060D	-60	60	Differential	6	850	85	1034	103	1034	103
M075D	-75	75	Differential	7.5	850	85	1034	103	1034	103
M100D	-100	100	Differential	10	1034	103	1034	103	1034	103
M160D	-160	160	Differential	16	1034	103	1034	103	1034	103
M250D	-250	250	Differential	25	1034	103	1034	103	1034	103
M500D	-500	500	Differential	50	2,000	200	1034	103	1034	103
MF25G	0	2.5	Gage	0.3	675	68	1034	103	1034	103
M005G	0	5	Gage	0.5	675	68	1034	103	1034	103
MF12G	0	12.5	Gage	1.25	675	67.5	1034	103	1034	103
M025G	0	25	Gage	2.5	750	75	1034	103	1034	103
M050G	0.0	50	Gage	5	850	85	1034	103	1034	103
M060G	0	60	Gage	6	850	85	1034	103	1034	103
M075G	0	75	Gage	7.5	850	85	1034	103	1034	103
M100G	0	100	Gage	10	850	85	1034	103	1034	103
M160G	0	160	Gage	16	1034	103	1034	103	1034	103
M250G	0	250	Gage	25	1034	103	1034	103	1034	103
M500G	0	500	Gage	50	1034	103	1034	103	1034	103
MN50G	-500	0	Gage	-50 to 0	1034	103	5171	517	17237	1724
M611A	600	1100	Absolute	60 to 110	1,034	103	5171	517	17237	1,724
CODE	P <sub>min</sub> bar	P <sub>max</sub>	Pressure Mode	kPa	bar	kPa	bar	kPa	bar	kPa
B001D	-1	1	Differential	100	3.1	310	10.3	1034	17.2	1724
BF25D	-2.5	2.5	Differential	250	7.2	720	17.2	1724	17.2	1724
B005D	-5	5	Differential	500	12.4	1240	17.2	1724	17.2	1724
B010D	-10	10	Differential	1000	17	1700	17.2	1724	17.2	1724
BN01G	-1	0	Gage	-100 to 0	2	200	5.2	517	17.2	1724
B001G	0	1	Gage	100	2	200	5.2	517	17.2	1724
BF25G	0	2.5	Gage	250	6.2	620	10.3	1034	17.2	1724
B005G	0	5	Gage	500	8	800	17.2	1724	17.2	1724
B010G	0	10	Gage	1000	17	1700	17.2	1724	17.2	1724
B001A	0	1	Absolute	100	1	100	1.0	103	1.0	103
B002A	0	2	Absolute	200	5	500	10.3	1034	17.2	1724

## ELVH Output Series Performance Table

Performance Specified At: 5V ± 5% for 5V Nominal Vs, 3.3V ± 5% for 3.3V Nominal Vs. Ref temp 25°C. Positive Pressure applied to Port B (top port).

Parameter	Digital					Analog				
	Min	Typ	Max	Units	Notes	Min	Typ	Max	Units	Notes
<b>Full Scale Span</b>										
(10% - 90%, 5% - 85% Transfer Function Options)										
xxxD (Differential)	-	±6554	-	Count (Dec)	5	-	±40% VS	-	V	5
xxxG (Gage), xxxA (Absolute)	-	13108	-	Count (Dec)	5	-	80% VS	-	V	5
(5% - 95%, 4% - 94% Transfer Function Options)										
xxxD (Differential)	-	±7373	-	Count (Dec)	5	-	±45% VS	-	V	5
xxxG (Gage), xxxA (Absolute)	-	14746	-	Count (Dec)	5	-	90% VS	-	V	5
<b>Offset</b>										
(10% - 90% Transfer Function Option)										
xxxD (Differential)	-	8192	-	Count (Dec)	-	-	50% VS	-	V	-
xxxG (Gage), xxxA (Absolute)	-	1638	-	Count (Dec)	-	-	10% VS	-	V	-
(5% - 95% Transfer Function Option)										
xxxD (Differential)	-	8192	-	Count (Dec)	-	-	50% VS	-	V	-
xxxG (Gage), xxxA (Absolute)	-	819	-	Count (Dec)	-	-	5% VS	-	V	-
(5% - 85% Transfer Function Option)										
xxxD (Differential)	-	7373	-	Count (Dec)	-	-	45% VS	-	V	-
xxxG (Gage), xxxA (Absolute)	-	819	-	Count (Dec)	-	-	5% VS	-	V	-
(4% - 94% Transfer Function Option)										
xxxD (Differential)	-	8028	-	Count (Dec)	-	-	49% VS	-	V	-
xxxG (Gage), xxxA (Absolute)	-	655	-	Count (Dec)	-	-	4% VS	-	V	-
<b>Accuracy</b>	-	-	±0.25	%FSS	6	-	-	±0.25	%FSS	6
<b>Full Scale Output Resolution</b>	-	14	-	bits	-	-	11	-	bits	-
<b>Total Error Band (TEB) - Industrial Temp. (-20°C to 85°C)</b>										
F50D, L01G, MF25G	-	-	±4	%FSS	7	-	-	±4	%FSS	7
L01D, L02G, M005G, MF25D	-	-	±3	%FSS	7	-	-	±3	%FSS	7
Remaining ranges	-	-	±2	%FSS	7	-	-	±2	%FSS	7
<b>Total Error Band (TEB) - Standard Temp. (0°C to 50°C)</b>										
F50D, L01G, MF25G	-	-	±3	%FSS	7	-	-	±3	%FSS	7
L01D, L02G, MF25D, M005G	-	-	±2	%FSS	7	-	-	±2	%FSS	7
L02D, L04G, M005D	-	-	±1.5	%FSS	7	-	-	±1.5	%FSS	7
Remaining ranges	-	-	±1	%FSS	7	-	-	±1	%FSS	7
<b>Position Sensitivity</b>										8
L02x, MF25x, & Below	-	±0.2	-	%FSS	8	-	±0.2	-	%FSS	
Above L02x & MF25x	-	±0.1	-	%FSS	8	-	±0.1	-	%FSS	
<b>Startup Time</b>	-	-	3	ms	-	-	-	5	ms	-
<b>Response Time</b>	-	0.46	-	ms	-	-	1	-	ms	-
<b>Supply Current</b>										
3.3V Supply Option	-	3.1	3.9	mA	-	-	2.1	2.8	mA	-
5V Supply Option	-	3.7	4.6	mA	-	-	2.7	3.5	mA	-

### ELVH Output Performance Specification Notes

Note 5: Full Scale Span (FSS) is the algebraic difference between the output signal for the highest and lowest specified pressure.

Note 6: Accuracy is the measured deviation based on Best Fit Straight Line (BFSL).

Note 7: Total Error Band is calculated from a combination of all possible errors, including offset, span temperature, calibration, linearity, pressure hysteresis, offset warm-up shift, offset position sensitivity, and long term offset drift.

### Temperature Output Conversion Function

$$\text{Temperature (}^{\circ}\text{C)} = \text{Tout}_{dig} \times \left( \frac{200}{2^{11} - 1} \right) - 50$$

### Transfer Function (A) 10 to 90% Example

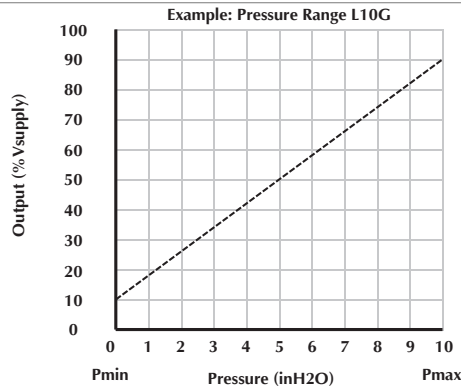

$$\text{Output (V)} = \frac{\text{Pressure}_{\text{applied}} - P_{\text{min}}}{P_{\text{max}} - P_{\text{min}}} \times ((0.9 - 0.1) \times V_{\text{supply}}) + 0.1 \times V_{\text{supply}}$$



# How to Order ELVH Series

For example, **ELVH-L01D-HAAH-C-NAA4** defines an All Sensors ELVH Series Analog + Digital Pressure Sensor, 1 inH2O differential pressure range, HAAH package (SIP H-Lead with barbed top ports), compensated temperature range from 0°C to 50°C, no parylene coating, diagnostics OFF, Analog output, 10 to 90% of Vsupply transfer function, 3.3 Vdc supply voltage.

**ELVH - L01D - HAAH - C - N A A 4**

Compensated Temperature Range

C	0°C to 50°C
I	-20°C to 85°C

Supply Voltage

4	3.3 Vdc
5	5.0 Vdc

Coating/Diagnostics

C	No Parylene, Diagnostics ON
E	Parylene, Diagnostics ON
N	No Parylene, Diagnostics OFF
P	Parylene, Diagnostics OFF

Transfer Function

A	10% to 90% (% of Vs for Analog, % of 2 <sup>14</sup> counts for Digital)
B	5% to 95% (% of Vs for Analog, % of 2 <sup>14</sup> counts for Digital)
C	5% to 85% (% of Vs for Analog, % of 2 <sup>14</sup> counts for Digital)
D	4% to 94% (% of Vs for Analog, % of 2 <sup>14</sup> counts for Digital)

Output Interface

	See Package Pinout Offering Code Legend			
	DIP (8 Pin)	SMT (8 Pin)	SIL (4 Pin)	
A	Analog, H-Style	3	3	4
S	SPI	2	2	Not Available
2	I <sup>2</sup> C, Address 0x28	1	1	5
3	I <sup>2</sup> C, Address 0x38	1	1	5
4	I <sup>2</sup> C, Address 0x48	1	1	5
5	I <sup>2</sup> C, Address 0x58	1	1	5
6	I <sup>2</sup> C, Address 0x68	1	1	5
7	I <sup>2</sup> C, Address 0x78	1	1	5

Pressure Ranges Note 10

Differential	Gage	Absolute
F50D ± 0.5 inH2O	L01G 0 to 1 inH2O	015A 0 to 15 psi
L01D ± 1 inH2O	L02G 0 to 2 inH2O	030A 0 to 30 psi
L02D ± 2 inH2O	L04G 0 to 4 inH2O	060A 0 to 60 psi
L04D ± 4 inH2O	L05G 0 to 5 inH2O	100A 0 to 100 psi
L05D ± 5 inH2O	L10G 0 to 10 inH2O	150A 0 to 150 psi
L10D ± 10 inH2O	L20G 0 to 20 inH2O	M611A 600 to 1100 mbar
L20D ± 20 inH2O	L30G 0 to 30 inH2O	B001A 0 to 1 bar
L30D ± 30 inH2O	L60G 0 to 60 inH2O	B002A 0 to 2 bar
L60D ± 60 inH2O	001G 0 to 1 psi	
001D ± 1 psi	005G 0 to 5 psi	
005D ± 5 psi	015G 0 to 15 psi	
015D ± 15 psi	030G 0 to 30 psi	
030D ± 30 psi	060G 0 to 60 psi	
060D ± 60 psi	100G 0 to 100 psi	
MF25D ± 2.5 mbar	150G 0 to 150 psi	
M005D ± 5 mbar	MF25G 0 to 2.5 mbar	
MF12D ± 12.5 mbar	M005G 0 to 5 mbar	
M025D ± 25 mbar	MF12G 0 to 12.5 mbar	
M050D ± 50 mbar	M025G 0 to 25 mbar	
M060D ± 60 mbar	M050G 0 to 50 mbar	
M075D ± 75 mbar	M060G 0 to 60 mbar	
M100D ± 100 mbar	M075G 0 to 75 mbar	
M160D ± 160 mbar	M100G 0 to 100 mbar	
M250D ± 250 mbar	M160G 0 to 160 mbar	
M500D ± 500 mbar	M250G 0 to 250 mbar	
B001D ± 1 bar	M500G 0 to 500 mbar	
BF25D ± 2.5 bar	MNS0G -500 to 0 mbar	
B005D ± 5 bar	BN01G -1 to 0 bar	
B010D ± 10 bar	B001G 0 to 1 bar	
	BF25G 0 to 2.5 bar	
	B005G 0 to 5 bar	
	B010G 0 to 10 bar	

Package Selection (4 Character Code) Note 10

DIP	SIP H-Lead	SMT J-Lead	SMT No Lead
—	HAAH ◦	—	—
HAND ◦	HANH ◦	HANJ ◦	—
HDRD * ◦	HDRH * ◦	HDRJ * ◦	—
HJJD	HJJH	HJJJ	—
HJND ◦	HJNH ◦	HJNJ ◦	—
HKND ◦	—	HKNJ ◦	—
HNND ◦	HNNH	HNNJ ◦	—
HRND ◦	HRNH	HRNJ ◦	—
HRRD	HRRH	HRRJ	HRRN ◦

Note 10: Parylene Coating is not available for pressure ranges below 10 inH2O and 25 mbar.

\* For gage, absolute and differential pressure, packages marked with a star are only available for pressure ranges

◦ For differential pressure, packages marked with a circle are only available for pressure ranges below 100 PSI.

◊ HRRN package is available for pressure ranges ≤ 5 PSI gage and differential and 15 PSI absolute.

**\*Package Pinout Offering Code Legend**

Pin Code	Pin 1	Pin 2	Pin 3	Pin 4	Pin 5	Pin 6	Pin 7	Pin 8
1	GND	VS	SDA	SCL	N/C	N/C	N/C	N/C
2	GND	VS	MISO	SCLK	SS	N/C	N/C	N/C
3	N/C	VS	VOUT	GND	N/C	N/C	N/C	N/C
4	N/C	VS	VOUT	GND	-	-	-	-
5	GND	VS	SDA	SCL	-	-	-	-

N/C: Not Internally Connected



## Device Options

---

### Parylene Coating:

Parylene coating provides a moisture barrier and protection from some harsh media. Unlike other pressure sensor suppliers offering a Parylene coating, All Sensors performs this process in-house and uses an advanced production system to achieve the highest accuracy and reliability. This avoids transferring products out of and back to the pressure sensor manufacturing facility, provides complete quality control and improves the delivery time to customers. Specially designed masking techniques allow All Sensors to apply a cost-effective, high-volume Parylene coating in-house.

Consult factory for applicability of Parylene for the target application and sensor type.

This option is not available for pressure ranges below  $\pm 10$  inH<sub>2</sub>O and  $\pm 25$ mbar configurations.

### Bridge Diagnostic:

If Diagnostics are ON, an electrical fault in the sensor bridge will cause the Error Condition to be set in the status bits as described in Tables 1 and 2 on page 11. If Diagnostics on OFF, a bridge fault will NOT cause the Error Condition to be set.

### Soldering Recommendations:

- 1) If possible, solder parts as a second operation only.
- 2) Post reflow and other high temperature processes, wait for 48 hrs before performing any calibration operations.
- 3) Perform spot cleaning as necessary only by hand. **DO NOT** wash or submerge device in cleaning liquid.
- 4) Max 270°C lead temperature (manual soldering 2-4 sec.)

If these devices are to be subjected to solder reflow assembly or other high temperature processing, they must be baked for 1 hour at 125°C within 24 hours prior to exposure. Failure to comply may result in cracking and/or delamination of critical interfaces within the package, and is not covered by warranty.

### Evaluation Kit:

All Sensors offers evaluation kits to help design engineers evaluate potential devices early in the development process.



## Sensor Application Information

---

### **Transfer Functions:**

Measurement systems employing ELVH sensors typically need to process the sensor output in terms of standard pressure units. Converting the sensor outputs to these units is done using the transfer function equations defined below.

Digital versions of ELVH sensors have an output range of 14 bits, or 0 to 16383 counts, referred to as the *Full Scale Range (FSR)*.

Analog ELVH analog versions have a corresponding output FSR from 0 volts (relative to sensor Ground pin) up to the sensor supply voltage ( $V_s$ ). Unlike digital sensors, which provide an output in digital counts independent of changes in  $V_s$ , the Analog output is rationometric, or proportional to the supply voltage.

Depending on the calibration Transfer Function option, the output at minimum and maximum calibrated pressures corresponds to different fractions of this Full Scale Range.

The **difference** in output at the maximum and minimum calibrated pressures is the *Full Scale Span (FSS)* of the sensor.

The general form of the equation for converting sensor output to pressure is:

$$P(\text{units}) = \text{Offset Pressure}(\text{Units}) + \left( \frac{\text{Sensor Output} - \text{Offset Output}}{\text{Full Scale Span}} \right) * \text{Calibrated Range}(\text{Units})$$

where

*Offset Pressure (Units)* is the minimum absolute value of pressure applied: for all Standard Gage, Differential, and Absolute products, this value is zero.

For Barometric Absolute ranges, this value is the lower limit of the range (e.g. 600 mbarA).

*Sensor Output* is the pressure reading, whether digital (in counts for I2C or SPI output) or analog (the sensor voltage output)

*Offset Output* is the sensor reading with no pressure applied; this is specified in the Performance Tables as **Offset**, for both digital and analog outputs. This value depends on the Transfer Function option selected.

*Full Scale Span* as defined above is the difference in output at maximum and minimum calibrated pressures. This is specified in the Performance Tables as **Full Scale Span**.

For ELVH Transfer Function options A and C (10%-90%, 5%-85% FSR), this corresponds to 80% of FSR; for ELVH Transfer Function options B and D (5%-95%, 4%-94% FSR), this corresponds to 90% of FSR.

Note that for Differential ranges, this is expressed as positive / negative values: this is to clarify the excursions above and below the offset value for positive / negative pressure.

## Sensor Application Information (Cont'd.)

---

Calibrated Range is the difference between highest and lowest calibrated pressures.  
For standard symmetrical Differential sensors, this is **twice** the maximum positive calibrated pressure.  
That is, for example, a 5 PSID pressure range would have a 10 PSI Calibrated Range.

For Analog sensors, it is important to note that the actual supply voltage ( $V_s$ ) is the reference for sensor readings, *not* the nominal calibration voltage (3.3V or 5V). Both Sensor Offset and Full Scale Span must be derived from  $V_s$  for correct interpretation of the sensor voltage output.

This requires normalizing the Performance Table values from the noted nominal  $V_s$  to actual  $V_s$ . In the case where an Analog to Digital converter is used, this is done simply by connecting the sensor  $V_s$  to the same supply rail as the ADC Reference Supply input.

### Transfer Function Calculation Examples:

#### Example 1: ELVH-L10G-xxxx-x-x2Ax

Calibrated from 0 to 10 inches H<sub>2</sub>O; I<sup>2</sup>C Digital output; 10% - 90% FSR transfer function.

Full Scale Span = 80% of FSR =  $0.8 * 16384 = 13108$ ; Offset Output = 1638

For a reading of 12250 counts, the pressure is then:

$$P_{out} = 0 + ((12250 - 1638)/13108) * 10 \text{ inH}_2\text{O}.$$

$$P_{out} = (10612/13108) * 10 \text{ inH}_2\text{O} = \mathbf{8.096 \text{ inH}_2\text{O}}.$$

#### Example 2: ELVH-005D-xxxx-x-xSBx

Calibrated from -5 to 5 PSI; SPI Digital output; 5% - 95% FSR transfer function.

Full Scale Span = 90% of FSR =  $0.9 * 16384 = 14746$ ; Offset Output = 8192.

The Calibrated Range is 5 PSI – (-5 PSI) = 10 PSI.

For a reading of 4250 counts, the pressure is then:

$$P_{out} = 0 + ((4250 - 8192)/14746) * 10 \text{ PSI}.$$

$$P_{out} = (-3942/14716) * 10 \text{ PSI} = \mathbf{-2.67 \text{ PSI}}.$$

#### Example 3: ELVH-030A-xxxx-x-xAA4

Calibrated from 0 to 30 PSIA; Analog output; 10% - 90% FSR transfer function, 3.3V *nominal* supply voltage.

For example, suppose that an *actual*  $V_s$  of 3.15V is present, not 3.30V.

The actual Full Scale Span is then:

$$FSS = 80\% \text{ of } V_s, = 0.80 * 3.15 = \mathbf{2.52V}.$$

The Offset is 10% FSR, or

$$\text{SensorOffset} = 0.10 * 3.15V = \mathbf{0.315V}.$$

For a reading of 1.775V, the pressure is then:

$$P_{out} = 0 + ((1.775V - 0.315V)/2.52V) * 30 \text{ PSIA}.$$

$$P_{out} = (1.463/2.52) * 30 \text{ PSIA} = \mathbf{17.38 \text{ PSIA}}.$$

#### Example 4: ELVH-M611A-xxxx-x-x4Dx

Calibrated from 600 to 1100 mbar; I<sup>2</sup>C Digital output; 4% - 94% FSR transfer function.

Full Scale Span = 90% of FSR =  $0.9 * 16384 = 14746$ ; Offset Output = 655.

Calibrated Span is (1100 mbar – 600 mbar) = 500 mbar.

For a reading of 7250 counts, the pressure is then:

$$P_{out} = 600 + ((7250 - 655)/14746) * 500 \text{ mbar}.$$

$$P_{out} = 600 + (6595/14746) * 500 \text{ mbar} = \mathbf{823.6 \text{ mbar}}.$$



## ELVH Digital Interface Data Format

For both I2C and SPI interface options, the data returned by the sensor is in the format shown:

**Table 1 - Output Data Format**

D[31:30]	D[29:24]	D[23:16]	D[15:8]	D[7:5]	D[4:0]
S[1:0]	P[13:8]	P[7:0]	T[10:3]	T[2:0]	X[4:0]
Status	Pressure MSB	Pressure LSB	Temperature MSB	Temperature LSB	Filler bits (Undefined)

Bit Definitions:

Status (S): Normal / busy / error

Pressure (P): Digital pressure reading

Temperature (T): Compensated temperature reading

**Table 2 - Status Bit Definitions**

[00]	[01]	[10]	[11]
Current Data, no errors.	(Reserved)	Stale Data: Not updated since last read.	Error Condition: electrical fault (if diagnostics enabled) or configuration invalid

## I2C Interface for ELVH Series

The I2C interface uses a set of signal sequences for communication. The following is a description of the supported sequences. Refer to Figure 1 for usage.

**Bus not Busy (I):** During idle periods both data line (SDA) and clock line (SCL) remain HIGH.

**START condition (ST):** A HIGH to LOW transition of SDA line while the clock (SCL) is HIGH is interpreted as START condition. START conditions are always set by the master. Each initial request for a pressure value has to begin with a START condition.

**Slave address (An):** The I2C-bus requires a unique address for each device. After setting a START condition the master sends the address byte containing the 7 bit sensor address followed by a data direction bit (R/W). A "0" indicates a transmission from master to slave (WRITE), a "1" indicates a data request (READ).

**Acknowledge (A or N):** Data is transferred in units of 8 bits (1 byte) at a time, MSB first. Each data-receiving device, whether master or slave, is required to pull the data line LOW to acknowledge receipt of the data. The Master must generate an extra clock pulse for this purpose. If the receiver does not pull the data line down, a NACK condition exists, and the slave transmitter becomes inactive. The master determines whether to send the last command again or to set the STOP condition, ending the transfer.

**DATA valid (Dn):** State of data line represents valid data when, after a START condition, data line is stable for duration of HIGH period of clock signal. Data on line must be changed during LOW period of clock signal. There is one clock pulse per data bit.

**DATA operation:** The sensor starts to send 4 data bytes containing the current pressure and temperature values. The transmission may be halted by the host after any of the bytes by responding with a NACK.

**STOP condition (P):** LOW to HIGH transition of the SDA line while clock (SCL) is HIGH indicates a STOP condition. STOP conditions are always generated by the master.

## I2C Exceptions

1. Sending a Start condition, then a Stop condition, without any transitions on the CLK line, creates a communication error for the next communication, even if the next start condition is correct and the clock pulse is applied. A second Start condition must be set, which clears the error and allows communication to proceed.
2. The Restart condition—a falling SDA edge during data transmission when the CLK clock line is still high— creates the same stall/deadlock. In the following data request, an additional Start condition must be sent for correct communication.
3. A falling SDA edge is not allowed between the start condition and the first rising SCL edge. If using an I2C address with the first bit 0, SDA must be held low from the start condition through the first bit.

**Figure 1 - I2C Communication Diagram**

### I2C Communications Diagram

1. Read Data ( with examples of reading pressure, pressure plus 8 bits of temperature and pressure plus 11 bits of temperature )

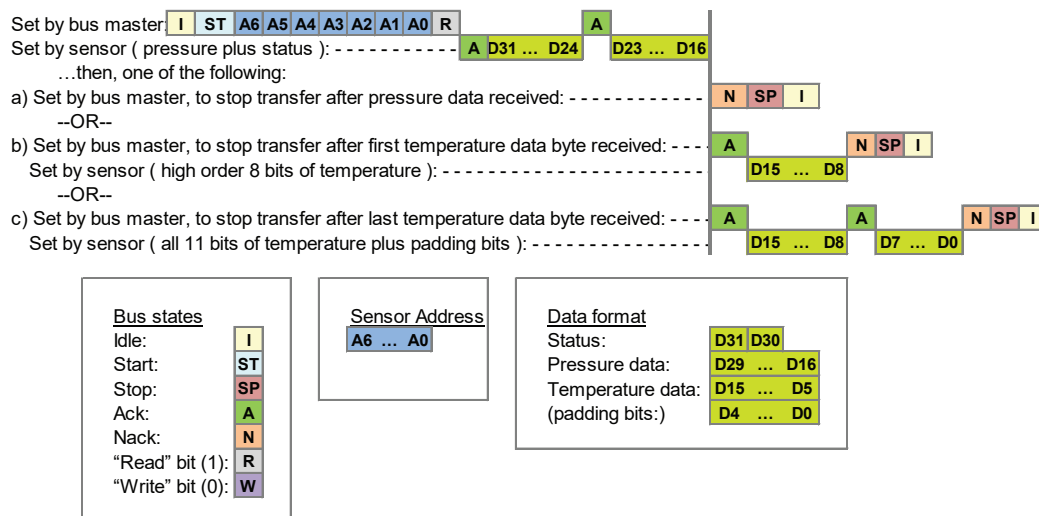

Figure 1 illustrates the sequence of signals set by both the host and the sensor for each command. Note that for the ReadData command, the host has the option of responding to the second or third bytes of data with a NACK instead of ACK. This terminates the data transmission after the pressure data, or after the pressure data and upper byte of temperature, have been transmitted. See Figure 4 for the I2C timing details.

## SPI Interface for ELVH Series

After power-up, the part enters Free Running mode and begins its periodic conversion cycle. The only bus interaction with the host is the SPI DataRead operation. Polling the sensor at a rate slower than the internal update rate will minimize bus activity and ensure that new values are presented with each transfer. Note that the Status bits should still be checked to verify updated data and the absence of error conditions.

ELVH sensors using the SPI interface option provide 3 signals for communication: SCLK, SS (Slave Select), and MISO.

### SPI Bit Pattern

The sequence of bits and bus signals are shown in the following illustration (Figure 2). Refer to Figure 3 in the Interface Timing Diagram section for detailed timing data. As previously described, the incoming data may be terminated by raising SS after 2, 3, or 4 bytes have been received as illustrated below.

**Figure 2 - SPI Bit Pattern**

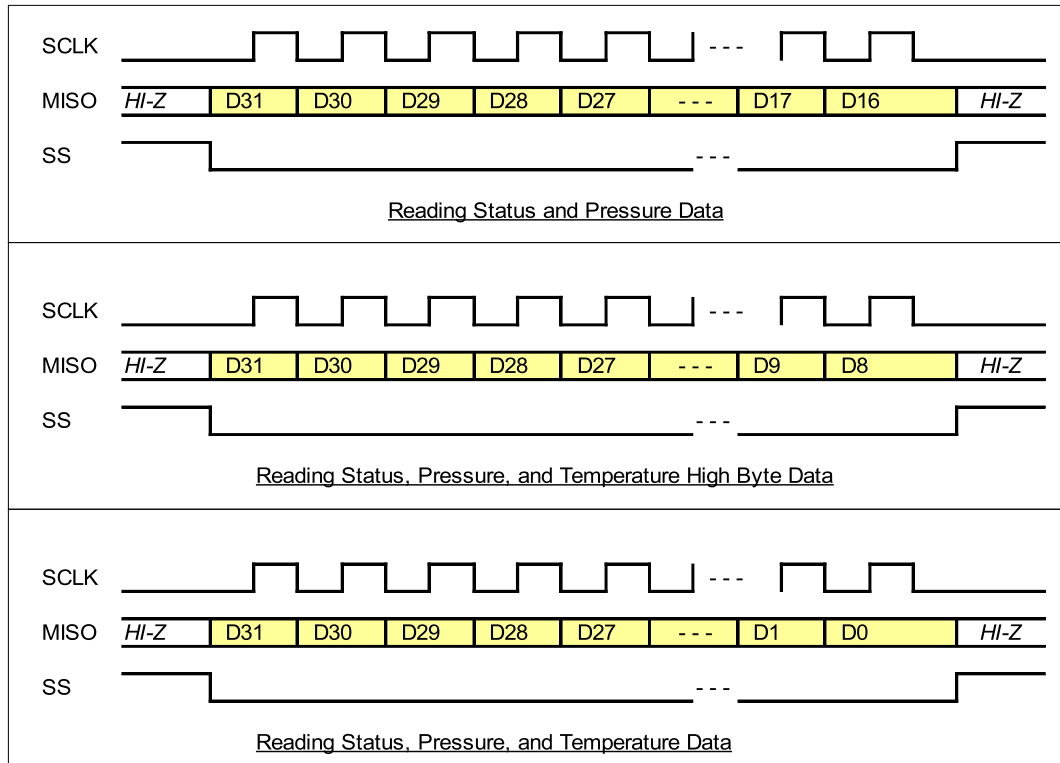

## Interface Timing Diagrams for ELVH Series

Figure 3 - SPI Timing Diagram

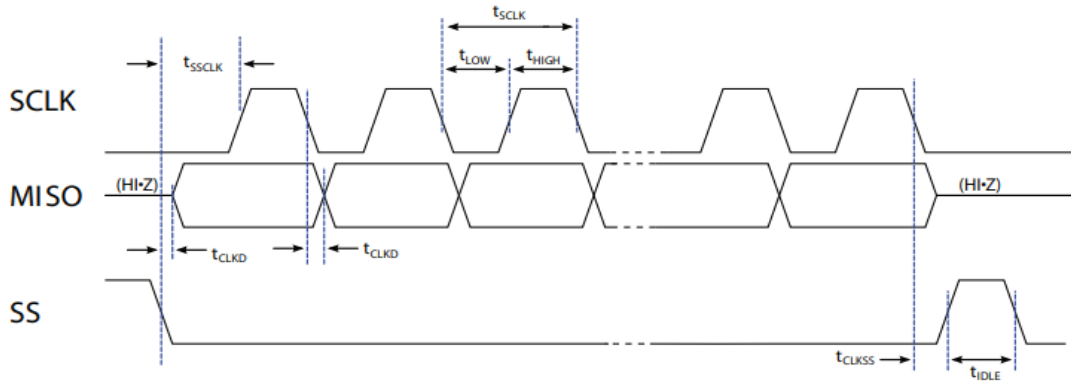

PARAMETER	SYMBOL	MIN	TYP	MAX	UNITS
S CLK clock frequency	$f_{SCLK}$	50	-	800	kHz
SS drop to first clock edge	$t_{SSCLK}$	2.5	-	-	$\mu$ s
Minimum S CLK clock low width	$t_{LOW}$	0.6	-	-	$\mu$ s
Minimum S CLK high width	$t_{HIGH}$	0.6	-	-	$\mu$ s
Clock edge to data transition	$t_{CLKD}$	0	-	0.1	$\mu$ s
Rise of SS relative to last clock edge	$t_{CLKSS}$	0.1	-	-	$\mu$ s
Bus free time between rise and fall of SS	$t_{IDLE}$	2	-	-	$\mu$ s

Figure 4 - I2C Timing Diagram

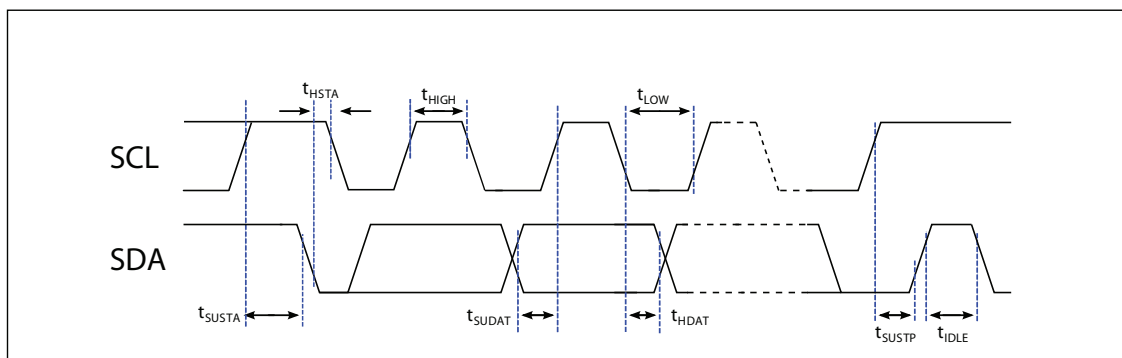

PARAMETER	SYMBOL	MIN	TYP	MAX	UNITS
SCL clock frequency	$f_{SCL}$	100	-	400	kHz
Start condition hold time relative to SCL edge	$t_{HSTA}$	0.6	-	-	kHz
Minimum SCL clock low width	$t_{LOW}$	0.6	-	-	$\mu$ s
Minimum SCL clock high width	$t_{HIGH}$	0.6	-	-	$\mu$ s
Start condition setup time relative to SCL edge	$t_{SUSTA}$	0.1	-	-	$\mu$ s
Data hold time on SDA relative to SCL edge	$t_{HDAT}$	0	-	-	$\mu$ s
Data setup time on SDA relative to SCL edge	$t_{SUDAT}$	0.1	-	-	$\mu$ s
Stop condition setup time on SCL	$t_{SUSTP}$	0.6	-	-	$\mu$ s
Bus free time between stop condition and start cond.	$t_{IDLE}$	2	-	-	$\mu$ s

## Pin Indicator

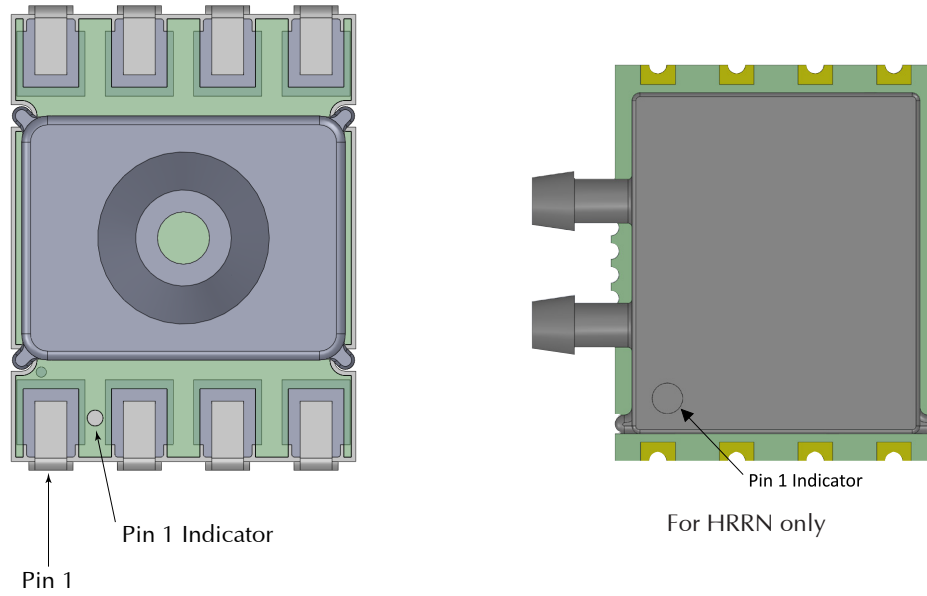

## Product Marking

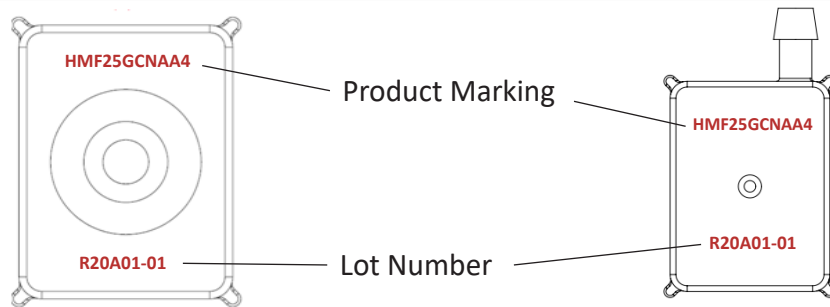

Example Product Marking: HMF25GCNAA4

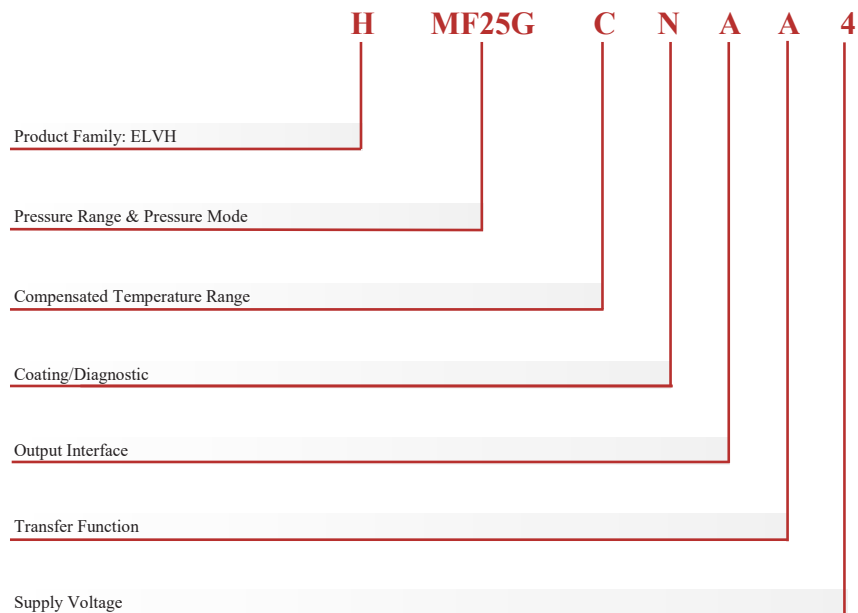

## Pressure Tubing Recommendations

Tubing Recommendations				
Lid Type	ID	OD	Material*	
			Low Pressure	High Pressure
A	5/32"	1/4"	Silicone	Polyurethane
R	1/16"	1/8"	Silicone	Polyurethane
J	1/16"	1/8"	Silicone	Polyurethane
K	3/32"	5/32"	Silicone	Polyurethane
N	O-ring face seal			

For the purposes of tubing recommendations, "Low Pressure" is defined as pressure ranges below 15 psi and "High Pressure" is defined as pressure ranges above 15 psi.

Note: 15 psi absolute is considered low pressure, whereas 15 psi differential and gage are considered high pressure.

## Suggested Pad Layouts

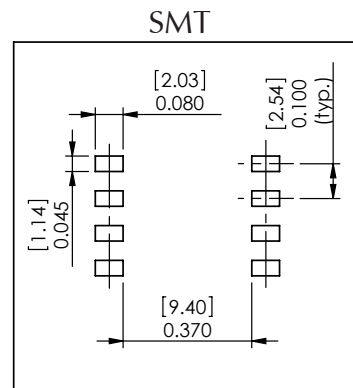
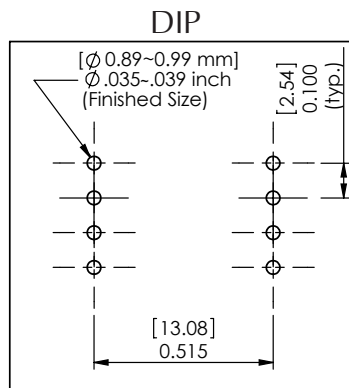
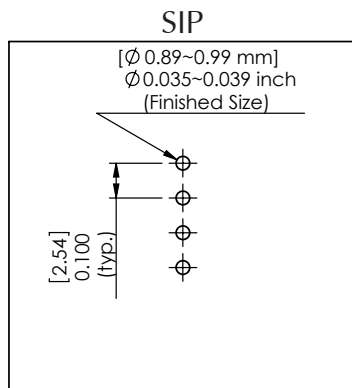

## Dimensional Drawings - DIP Packages

### Package Dimensions

DIP AN: Barbed Top Port Gage

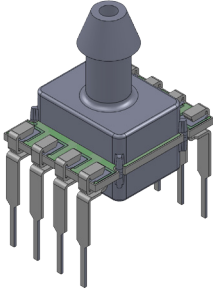

HAND Package

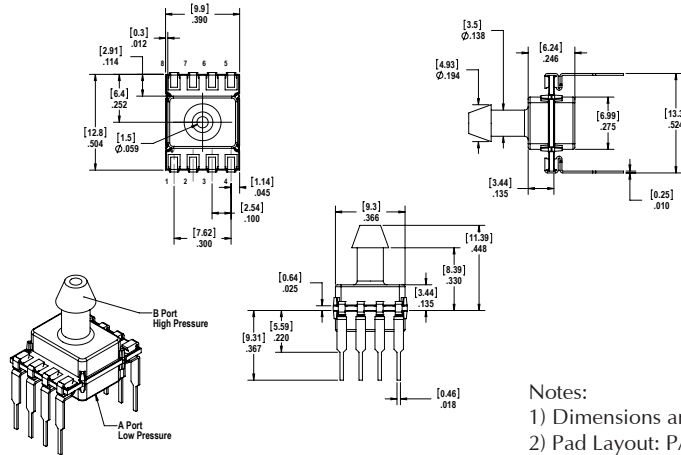

Notes:

- 1) Dimensions are in inches [mm].
- 2) Pad Layout: PAD-31.

DIP DR: Barbed Opposite Side Port Differential

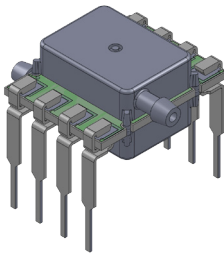

HDRD Package

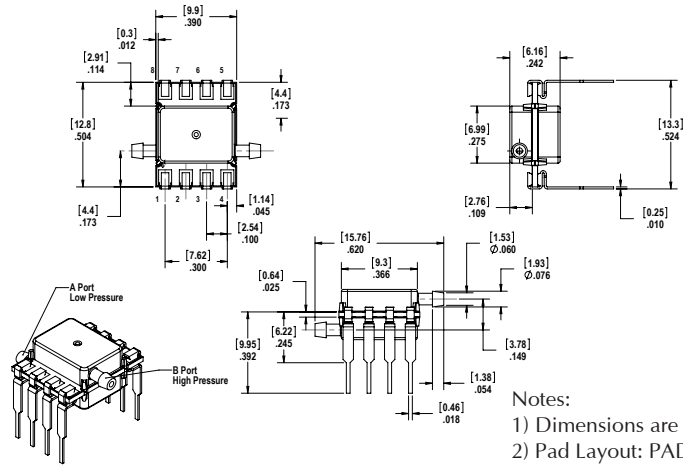

Notes:

- 1) Dimensions are in inches [mm].
- 2) Pad Layout: PAD-31.

DIP JN: Non-Barbed Tapered Side Port

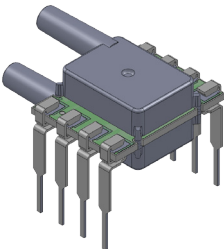

HJJD Package

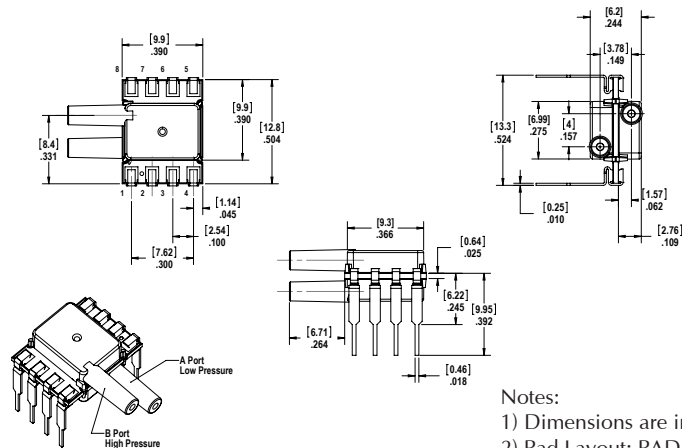

Notes:

- 1) Dimensions are in inches [mm].
- 2) Pad Layout: PAD-31.

\* Refer to How to Order Tables for pinouts

## Dimensional Drawings - DIP Packages (Cont'd.)

### Package Dimensions

DIP JN: Non-Barbed Tapered Side Port

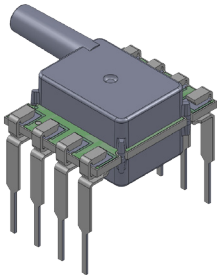

HJND Package

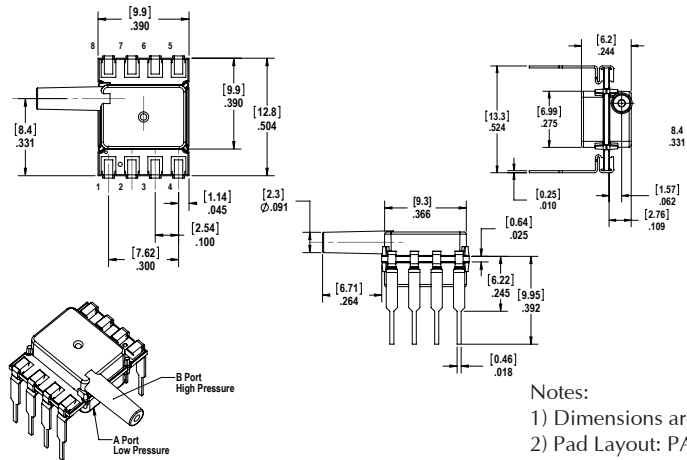

Notes:

- 1) Dimensions are in inches [mm].
- 2) Pad Layout: PAD-31.

DIP NN: No Port (Flat)

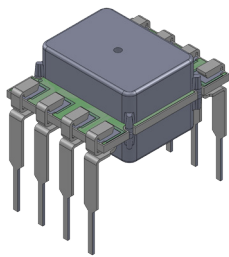

HNND Package

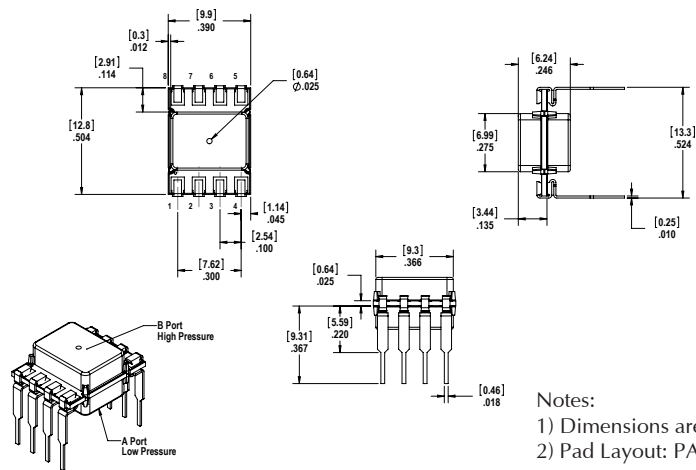

Notes:

- 1) Dimensions are in inches [mm].
- 2) Pad Layout: PAD-31.

DIP RN: Barbed Side Port Gage

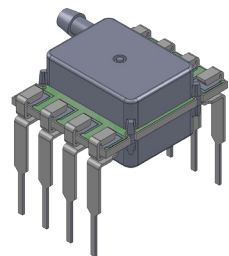

HRND Package

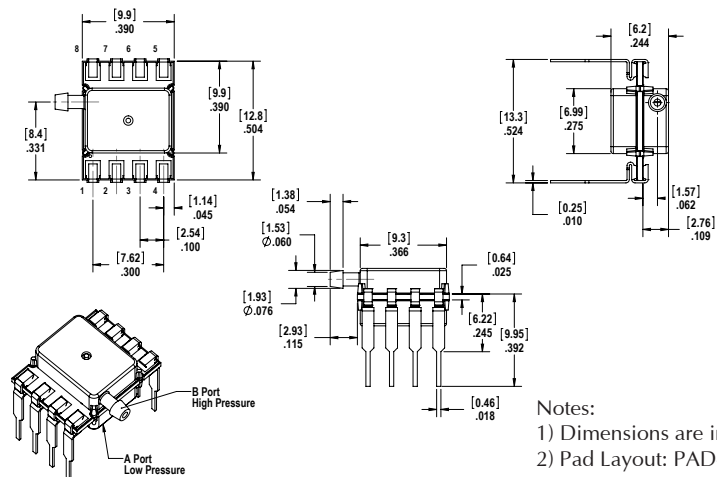

Notes:

- 1) Dimensions are in inches [mm].
- 2) Pad Layout: PAD-31.

\* Refer to How to Order Tables for pinouts

## Dimensional Drawings - DIP Packages (Cont'd.)

### Package Dimensions

DIP RR: Barbed Side Port  
Differential

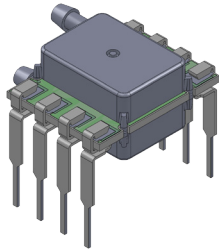

HRRD Package

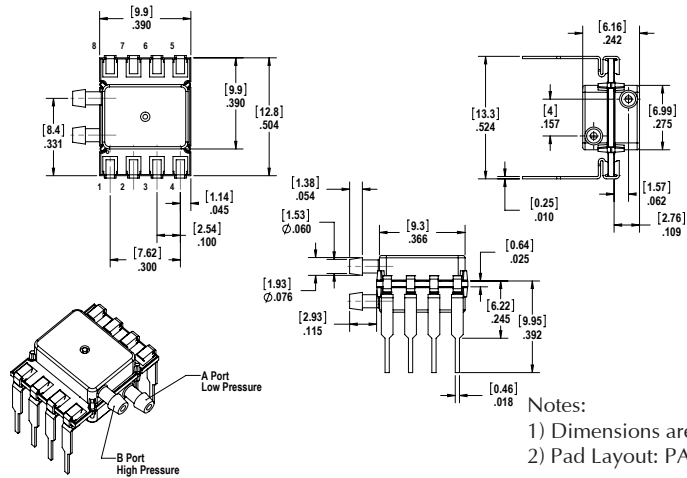

DIP KN: Non-Barbed Needle Top  
Port

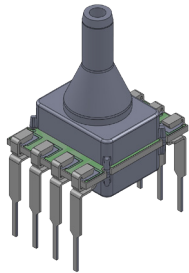

HKND Package

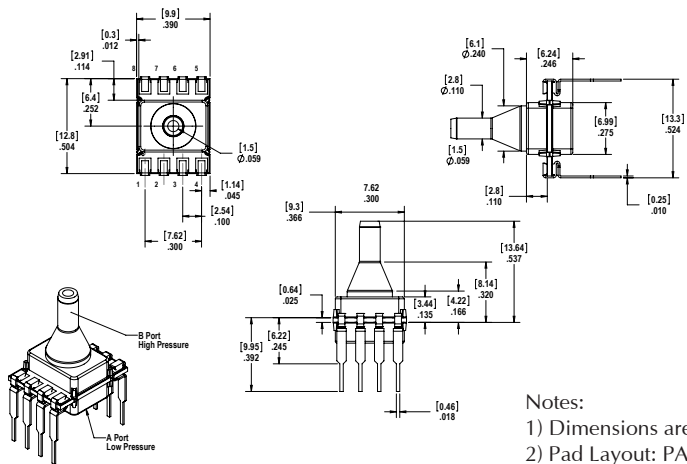

\* Refer to How to Order Tables for pinouts

# Dimensional Drawings - SIP Packages

## Package Dimensions

**SIP H-Lead AA: Barbed Top Port Differential**

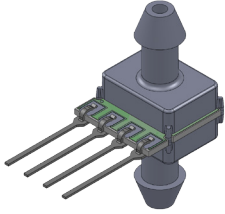

**HAAH Package**

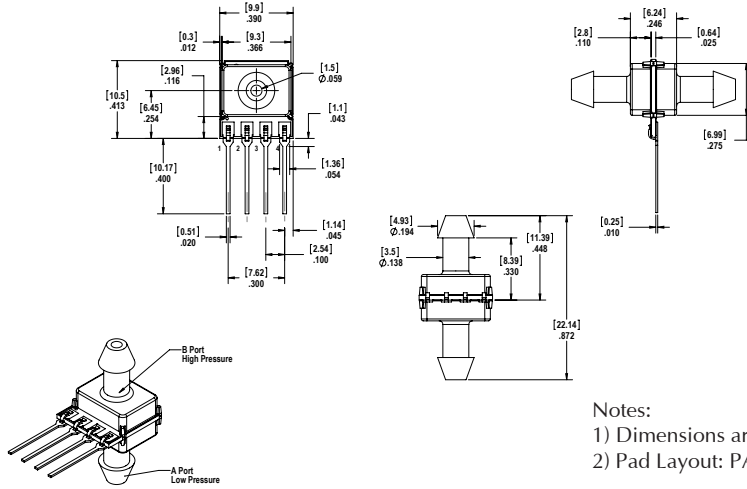

Notes:  
 1) Dimensions are in inches [mm].  
 2) Pad Layout: PAD-1.

**SIP H-Lead AN: Barbed Top Port Gage**

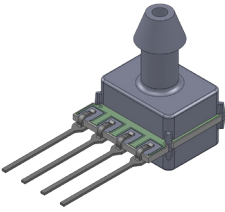

**HANH Package**

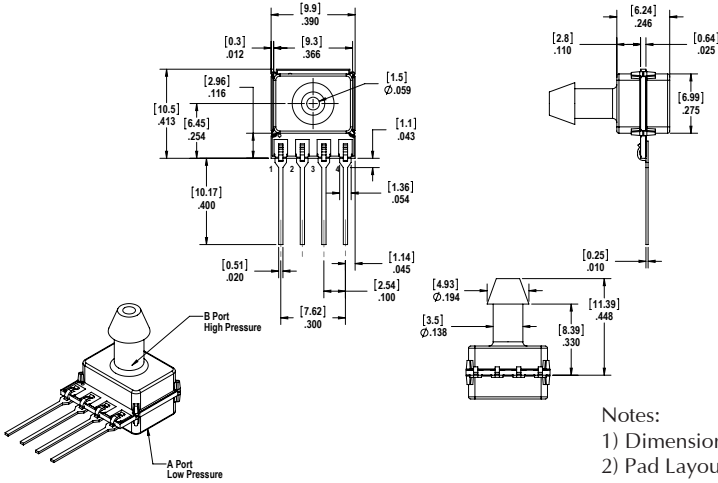

Notes:  
 1) Dimensions are in inches [mm].  
 2) Pad Layout: PAD-1.

**SIP H-Lead DR: Barbed Opposite Side Port Differential**

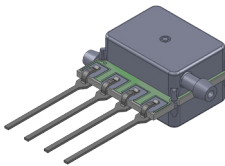

**HDRH Package**

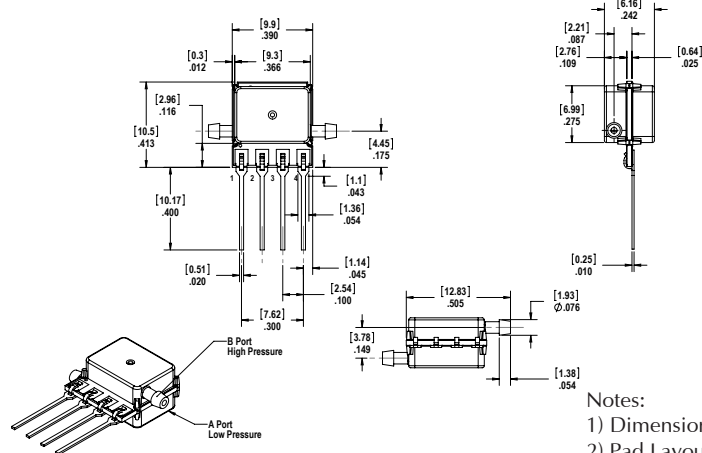

Notes:  
 1) Dimensions are in inches [mm].  
 2) Pad Layout: PAD-1.

\* Refer to How to Order Tables for pinouts



## Dimensional Drawings - SIP Packages (Cont'd.)

### Package Dimensions

**SIP H-Lead JJ: Non-Barbed  
Tapered Side Port**

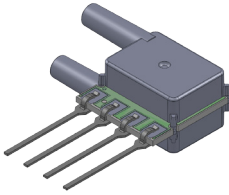

HJJH Package

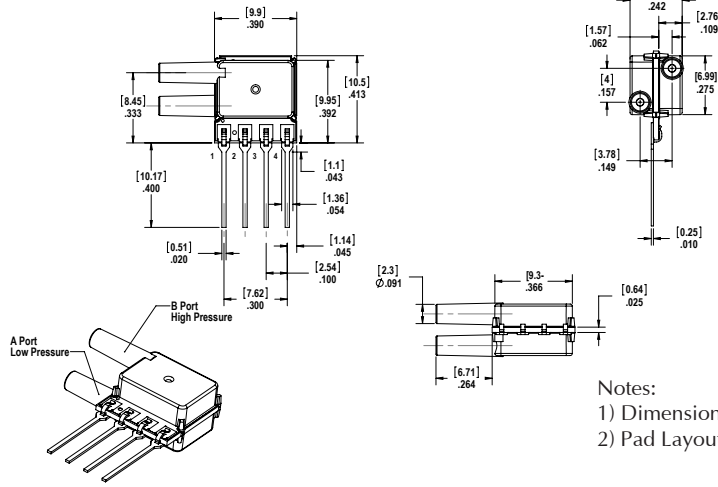

Notes:  
1) Dimensions are in inches [mm].  
2) Pad Layout: PAD-1.

**SIP H-Lead JN: Non-Barbed  
Tapered Side Port**

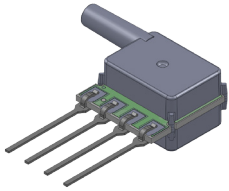

HJNH Package

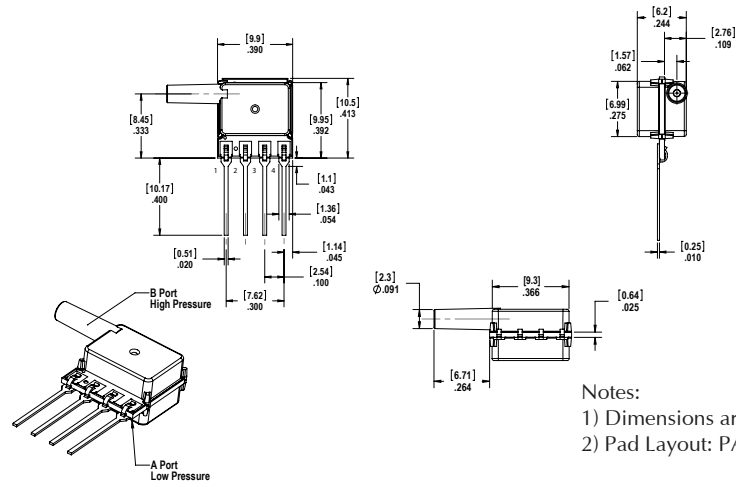

Notes:  
1) Dimensions are in inches [mm].  
2) Pad Layout: PAD-1.

**SIP H-Lead NN: No Port (Flat)**

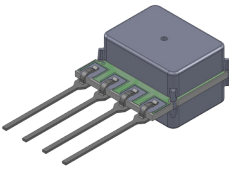

HNNH Package

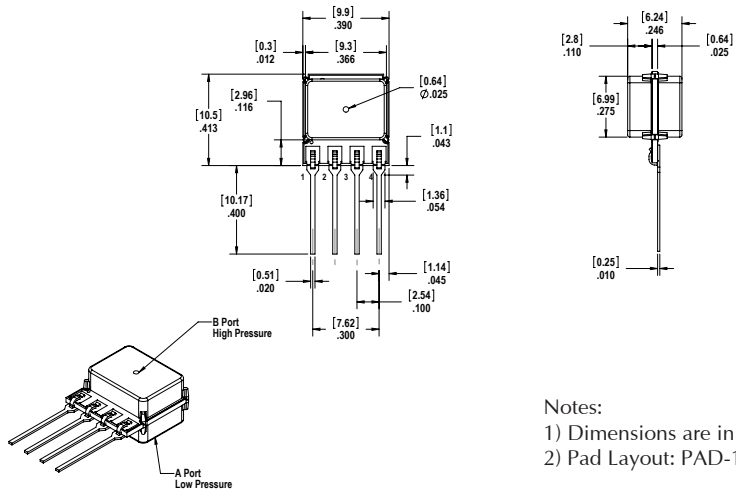

Notes:  
1) Dimensions are in inches [mm].  
2) Pad Layout: PAD-1.

\* Refer to How to Order Tables for pinouts



## Dimensional Drawings - SIP Packages (Cont'd.)

### Package Dimensions

SIP H-Lead RN: Barbed Side Port Gage

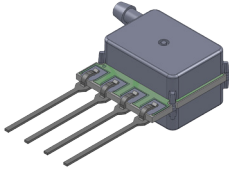

HRNH Package

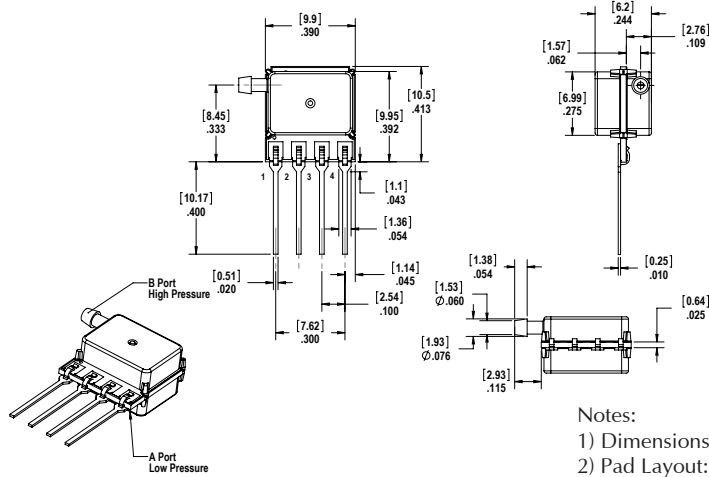

- Notes:  
 1) Dimensions are in inches [mm].  
 2) Pad Layout: PAD-1.

SIP H-Lead RR: Barbed Side Port Differential

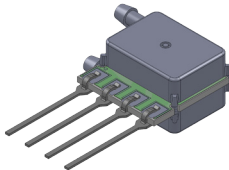

HRRH Package

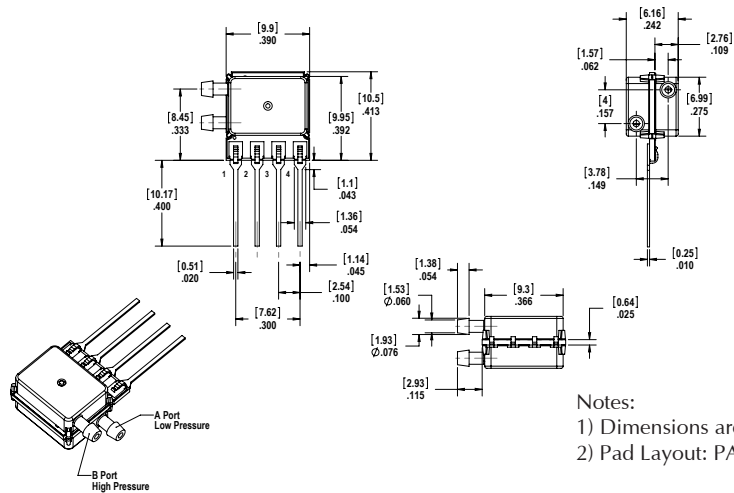

- Notes:  
 1) Dimensions are in inches [mm].  
 2) Pad Layout: PAD-1.

\* Refer to How to Order Tables for pinouts

# Dimensional Drawings - SMT Packages

## Package Dimensions

**SMT AN:** Barbed Top Port Gage

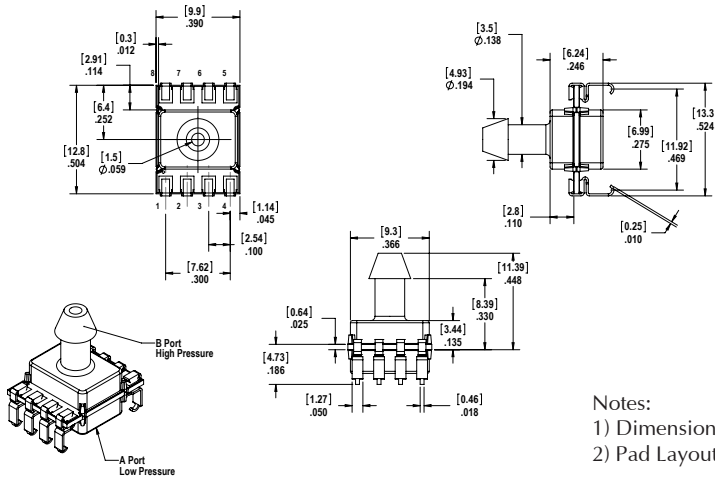
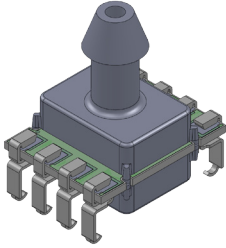

**HANJ Package**

**SMT DR:** Barbed Opposite Side Port Differential

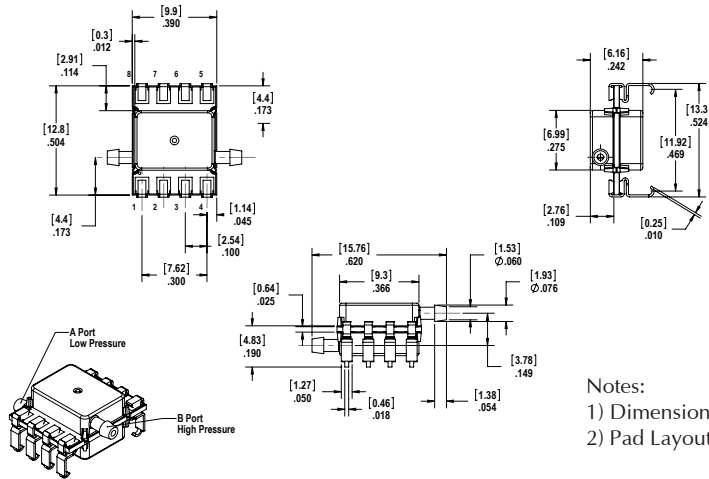
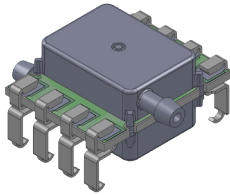

**HDRJ Package**

**SMT JJ:** Non-Barbed Tapered Side Port

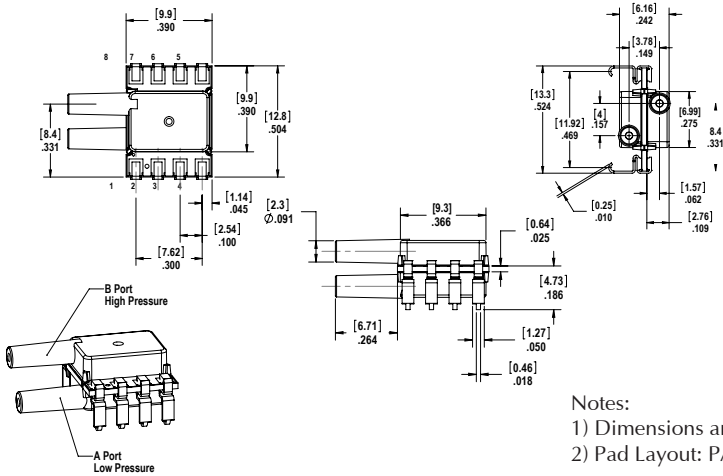
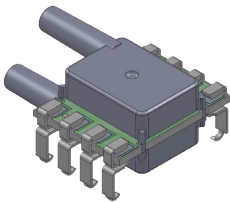

**HJJJ Package**

\* Refer to How to Order Tables for pinouts



## Dimensional Drawings - SMT Packages (Cont'd.)

### Package Dimensions

**SMT JN:** Non-Barbed Tapered Side Port

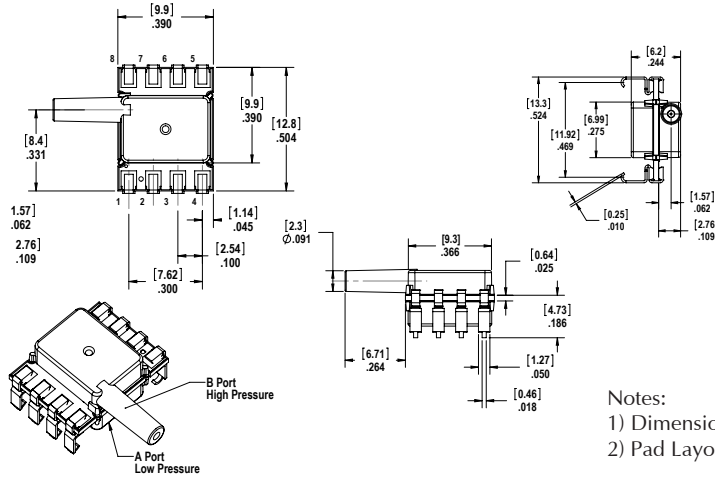
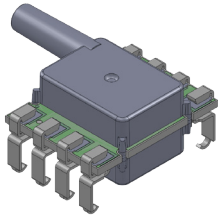

**HJNJ Package**

**SMT NN:** No Port (Flat)

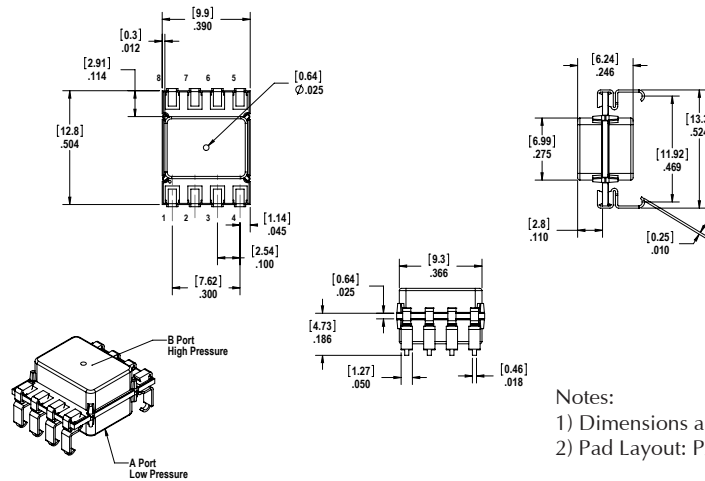
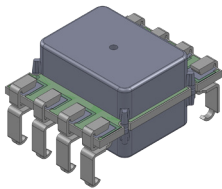

**HNNJ Package**

**SMT RN:** Barbed Side Port Gage

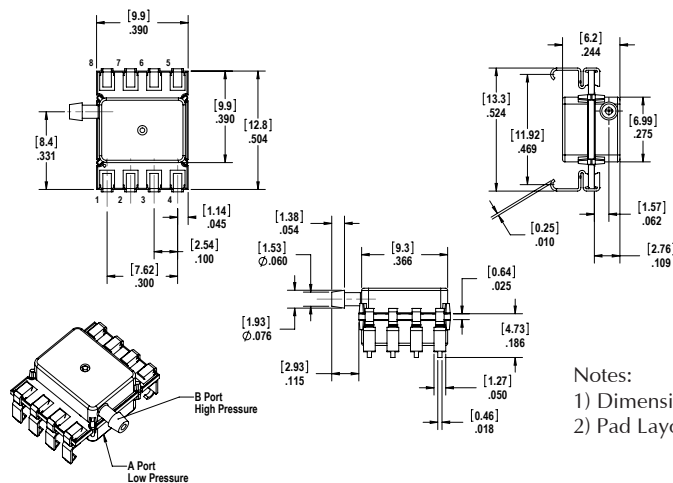
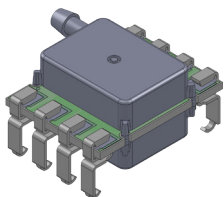

**HRNJ Package**

\* Refer to How to Order Tables for pinouts

# Dimensional Drawings - SMT Packages (Cont'd.)

## Package Dimensions

**SMT RR: Barbed Side Port Differential**

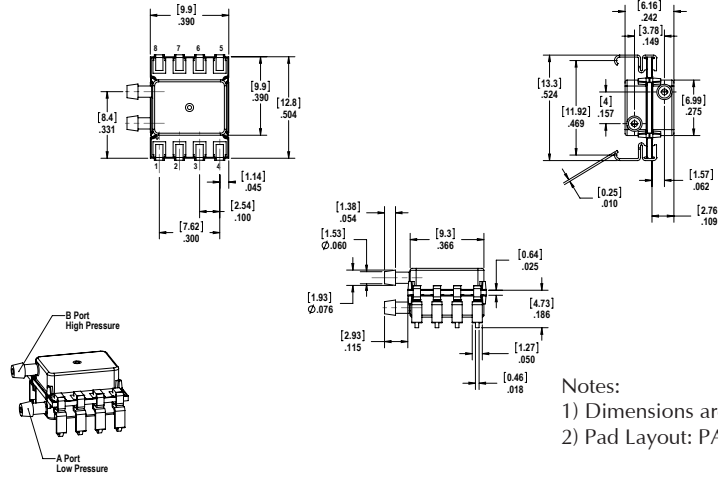
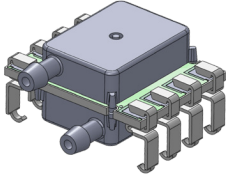

Notes:  
1) Dimensions are in inches [mm].  
2) Pad Layout: PAD-32.

### HRRJ Package

**SMT KN: Non-Barbed Needle Top Port**

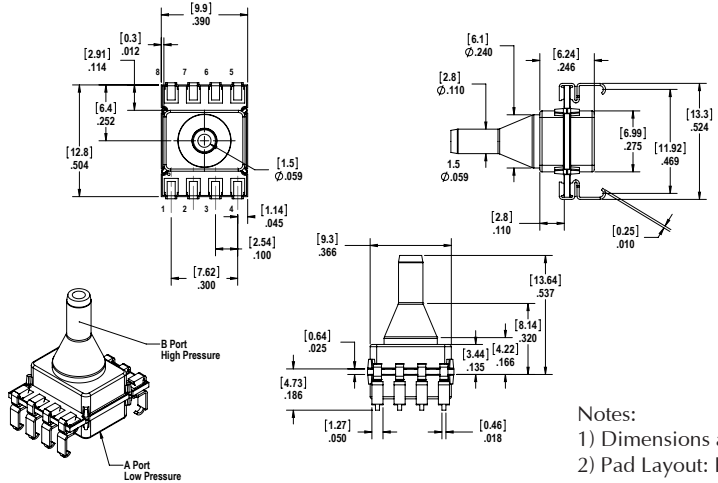
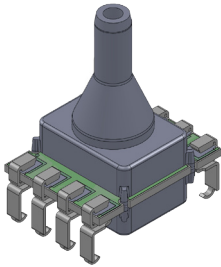

Notes:  
1) Dimensions are in inches [mm].  
2) Pad Layout: PAD-32.

### HKNJ Package

**SMT RR: Barbed Side Port No Lead**

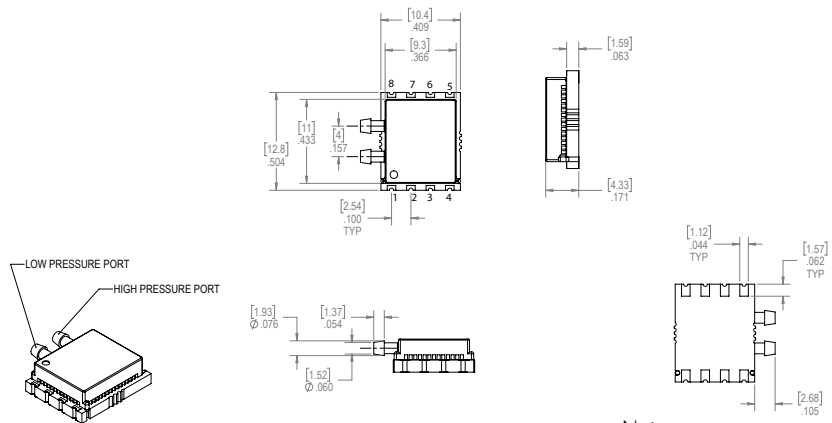
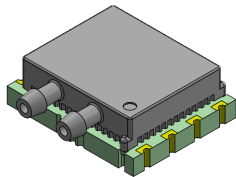

Notes:  
1) Dimensions are in inches [mm].  
2) Pad Layout: PAD-32.

### HRRN Package

\* Refer to How to Order Tables for pinouts

All Sensors reserves the right to make changes to any products herein. All Sensors does not assume any liability arising out of the application or use of any product or circuit described herein, neither does it convey any license under its patent rights nor the rights of others.

